

**AUTOMATIC
VALVES**

THE SOLUTION YOU'VE BEEN LOOKING FOR

LAROX AUTOMATIC VALVES

Larox automatic valves are ideal for shut off or control applications that involve abrasive or corrosive slurries, powders or granular substances. Our advanced flow control solutions meet even the most stringent customer specifications. Larox valves offer substantial savings through improved performance, longer service lifetime and lower maintenance costs.

TECHNICAL FEATURES

- 100% Tight
- Full Bore
- Only the Sleeve is in Contact with the Medium
- Linear Control Curve
- Centerline Closing
- Flexible Sleeve

PROCESS BENEFITS

- Excellent Wear Resistance
- High Corrosion Resistance
- No Jamming or Clogging
- Self-cleaning
- Trouble-free Operation
- Long Service Intervals
- Low Maintenance Costs
- Reduced Cost of Ownership

Over 50,000 Larox valves are currently operating in mining and metal industries, minerals processing, pulp and paper, chemical process industries, energy as well as oil and offshore industries. Numerous applications also exist in water and effluent treatment, dairy, food and beverage production, and pharmaceutical processing plants.

MODULAR DESIGN

Our modular valve design has three main components: the sleeve, the body and the actuator. The sleeve is the only part that is in contact with the process medium. The construction and materials of all three main

components can be tailored to suit most process conditions. Self-cleaning Larox valves provide 100% tight shut-off even if solids have built up on the sleeve wall. When compressed, any crystallized particles flake off the sleeve surface and are washed downstream.

The standard range is for diameters from 25 mm to 1,000 mm, temperatures from -50°C to +160°C, and operating pressures from vacuum to 100 bar.

We provide tailor-made flow control solutions precisely in accordance with the customer specifications.

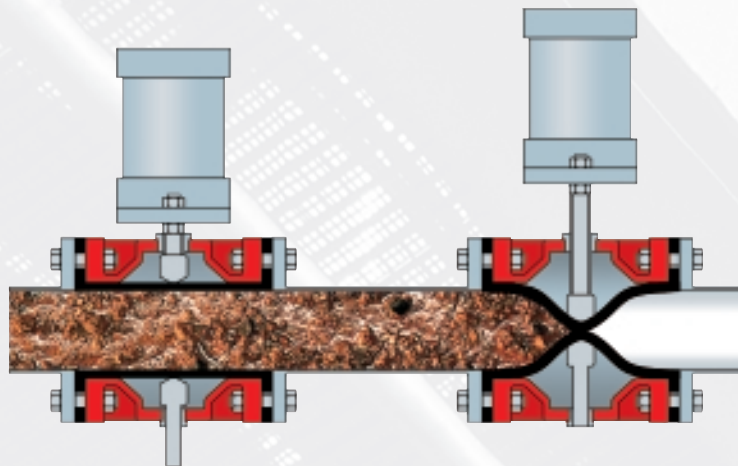

The operating principle of a Larox valve is simple. In the open position, the valve is at full bore with no flow restrictions thus making the valve an integral part of the pipeline. During closing, two pinch bars squeeze the sleeve shut on the centerline.

ACTUATED ON-OFF VALVES

The actuated on-off valves are ideal when remote control is required. The type of actuator depends on the operating pressure, availability of power sources and other process requirements.

PNEUMATIC ACTUATOR (A)

The standard pneumatic actuator is double acting, therefore allowing fast opening and closing. Actuator housing, tie rods and piston rods are available in various materials. Short cycle times are achieved by using quick exhaust valves.

Pneumatic actuators are suitable for a wide range of industrial applications. Epoxy paint can be applied to further improve corrosion resistance. The standard pneumatic actuators are simple and economical to install.

FAIL-SAFE OPTIONS

Pneumatic actuators can be equipped with an override (AB) hand wheel for manual fail-safe and a mechanical (AV) or a pneumatic spring (AU) for automatic fail-safe function.

HYDRAULIC ACTUATOR (H)

The compact, double acting hydraulic actuator is designed for applications where high closing forces are required (high operating pressure or large valve diameters). Epoxy painted actuators can be equipped with a pilot operated check valve for fail-safe function.

ELECTRIC ACTUATOR (E)

The standard double acting electric actuator incorporates built-in limit and torque switches, as well as a manual override hand wheel. Electric actuators are best suited for applications requiring high closing forces such as large valve diameters or high operating pressures. It is the recommended actuator for operating conditions where pneumatic and hydraulic power is unavailable.

SPECIAL ACTUATORS

THE PNEUMATIC MOTOR DRIVEN ACTUATOR is ideal for high force applications with limited space.

HYDRAULIC ACTUATORS with an integrated power unit are electrically driven stand-alone hydraulic units. The need for hydraulic piping is eliminated as they are mounted directly onto the actuator.

THE WATER HYDRAULIC ACTUATOR is best suited for applications where extreme cleanliness or fire safety is required and the use of hydraulic oil is unacceptable.



PVE 100 A6



PVE 100 H6



PVE 100 E10

VALVE MODEL SELECTION

EXAMPLE: PVE100AK10 - 203LR

PVE	100	AK	10	-	2	0	3	L	R
TYPE	SIZE (DN)	ACTUATOR	PRESSURE CLASSES (PN)		FLANGE DRILLINGS	BODY MATERIAL *	FLANGE SHAPE	OPENING TAGS	AUXILIARIES
PV = open	25-1000	A = pneumatic	1 = 1 bar		1 = -	0 = Fe	types 1 - 4	L = opening tags	Q = quick exhaust valve
PVE = enclosed		AB = with manual override	6 = 6 bar		2 = DIN PN 10	1 = -	Determined by the valve manufacturer		R = inductive limits
PVE/S = enclosed/sealed		AK = with electro-pneumatical positioner	10 = 10 bar		3 = DIN PN 16	2 = AISI 316			S = magnetic limits
PVS = sealed		AN = with pneumatical positioner	16 = 16 bar		4 = DIN PN 25	3 = aluminium			T = mechanical limits
		AV = with pneumatical spring	25 = 25 bar		5 = DIN PN 40	4 = other			Z = solenoid valve
		AU = with pneumatical spring	40 = 40 bar		6 = ANSI 150	5 = plastic			X = other, must be specified
		HP = with hydraulic positioner	64 = 64 bar		7 = ANSI 300				
		H = hydraulic	100 = 100 bar		8 = BS TABLE D				
		EO = electric for control			9A = AS TABLE D				
					9B = AS TABLE E				
					9C = JIS 10				
					9D = JIS 16				
					X = other, must be specified				

- *) Fe DN25-200: GRS 250 (EN-GJL-250), epoxy painted K18-E180/2-FeSa 2Ω
 DN250...: fabricated Fe37B (EN 10025 S235JRG2), epoxy painted K180-E180/2-FeSa 2Ω
- AISI 316 DN25-200: casted (EN 10213-4 1.4408)
 DN250...: fabricated (EN 10088-2 1.4432)
- Aluminium DN25-150: aluminium alloy (EN 1706 EN AC 44200) epoxy painted K18-E180/2-FeSa 2Ω
- Plastic Ciba 5000 series DN65---150; PA Blend DN250

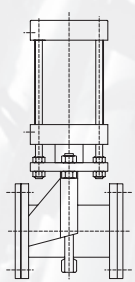

PV

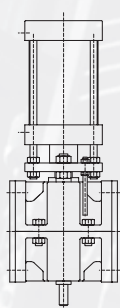

PVE

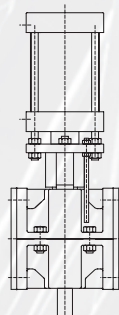

PVE/S

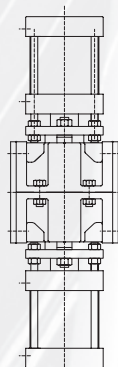

PVS

R



Z



S



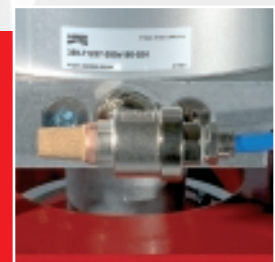

Q



SLEEVE MODEL SELECTION

EXAMPLE: SBRT 10100/250/3L2

SBRT	10	100	/	250	/	3	L	2
SLEEVE MATERIALS	PRESSURE CLASSES (PN)	SLEEVE INNER DIAMETER (MM)		SLEEVE LENGTH (MM)		FLANGE SHAPE	OPENING TAGS	FLANGE DRILLINGS
SBRT = styrene butadiene	1 = 1 bar	25 - 1000		Depends on the sleeve inner diameter		type 1	L = yes	1 = -
EPDM= ethylene propylene	6 = 6 bar						- = none	2 = DIN PN 10
CR = chloroprene	10 = 10 bar					type 3		3 = DIN PN 16
CSM = cloro-sulphone-ethene	16 = 16 bar							4 = DIN PN 25
FPM = fluorine rubber	25 = 25 bar					type 4		5 = DIN PN 40
HNBR= hydrogenated nitrile	40 = 40 bar							6 = ANSI 150
IIR = butyl	64 = 64 bar							7 = ANSI 300
NBR = nitrile	100 = 100 bar							8 = BS TABLE D
NBRF = nitrile foodstuff quality								9A = AS TABLE D
NR = natural rubber								9B = AS TABLE E
NRF = natural rubber foodstuff quality						9C = JIS 10		
PU = polyurethane						9D = JIS 16		
_/PU = PU coating inside the sleeve						X = other, must be specified		
_/M = Larox SensoMate sleeve								
						Determined by the valve manufacturer (depending on the valve diameter / pressure class)		

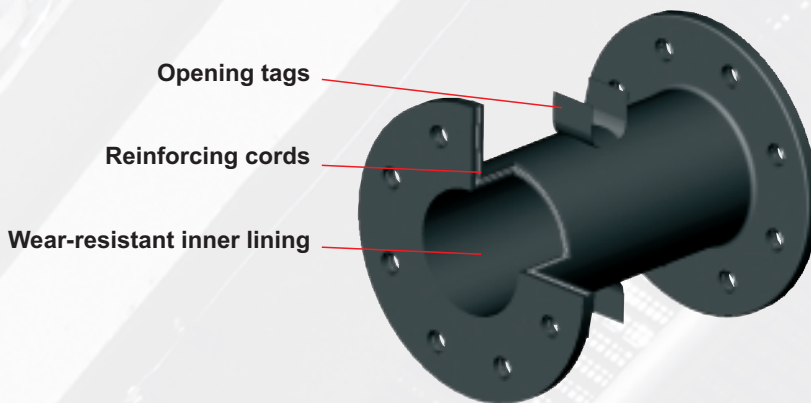

CONTROL VALVES FOR DEMANDING DUTIES

Larox control valves are designed for demanding control applications in which conventional valves encounter problems with turbulence and wear. Controllability can be further improved with conical sleeves or smart positioners. Elastic sleeves have been applied for improved wear resistance.

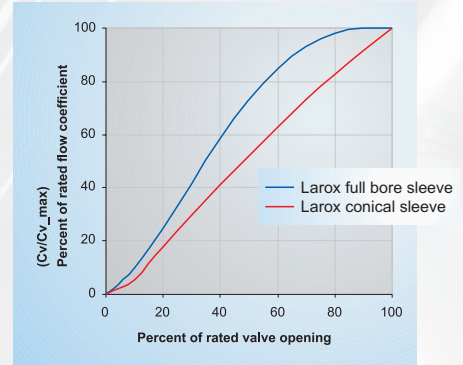

STANDARD POSITIONERS

Larox control valve actuator is equipped with a positioner. The standard positioners for various actuators are as follows:

For Pneumatic Actuators

- Electro-pneumatic (AK), input signal 4 - 20 mA
- Pneumatic (AN), input signal 0.2 - 1 bar

For Hydraulic Actuators

- Electro-hydraulic (HP), input signal 4 - 20 mA

For Electric Actuator

- Electronic (EO), input signal 4 - 20 mA



Control valve PVE 100 AK1

$$C_v = \frac{Q}{N_1 F_P F_R} \sqrt{\frac{G}{\Delta p}}$$

in which

Q = Volume flow rate
G = Specific gravity
 Δp = Pressure drop
N1 = Numerical constant
FP = Piping geometry factor
FR = Reynolds number

Larox control valve sizing is based on the IEC60534 standard (harmonized with ANSI/ISA S75 standards). The valve flow coefficient Cv defines the control valve flow capacity i.e. the valve size (diameter).

CV VALUES - FULL BORE SLEEVES

DIAMETER MM	25	32	40	50	65	80	100	125	150	200	250	300	350	400
OPENING %														
0	0	0	0	0	0	0	0	0	0	0	0	0	0	0
10	10	16	25	39	65	98	154	241	347	616	963	1387	1888	2465
20	24	39	61	96	162	246	384	601	865	1537	2402	3459	4708	6150
30	40	66	103	162	273	414	647	1010	1455	2586	4042	5820	7922	10347
40	57	93	145	226	382	579	905	1414	2037	3621	5657	8147	11089	14483
50	72	116	181	284	479	725	1134	1772	2552	4536	7099	10207	13893	18146
60	82	135	211	329	557	843	1317	2059	2964	5270	8234	11857	16139	21080
70	90	148	232	362	612	927	1448	2263	3258	5792	9050	13032	17738	23169
80	95	156	244	381	645	976	1525	2384	3432	6102	9534	13729	18687	24407
90	96	157	248	388	657	994	1554	2428	3497	6216	9713	13986	19037	24864
100	96	158	248	388	657	994	1554	2428	3497	6216	9713	13986	19037	24864

Cv tables for conical sleeves and larger diameters are available upon request. Contact Larox Flowsys (www.larox.fi/flowsys/) for a complementary Larox control valve sizing program.

MAIN DIMENSIONS

OPEN AND ENCLOSED BODY

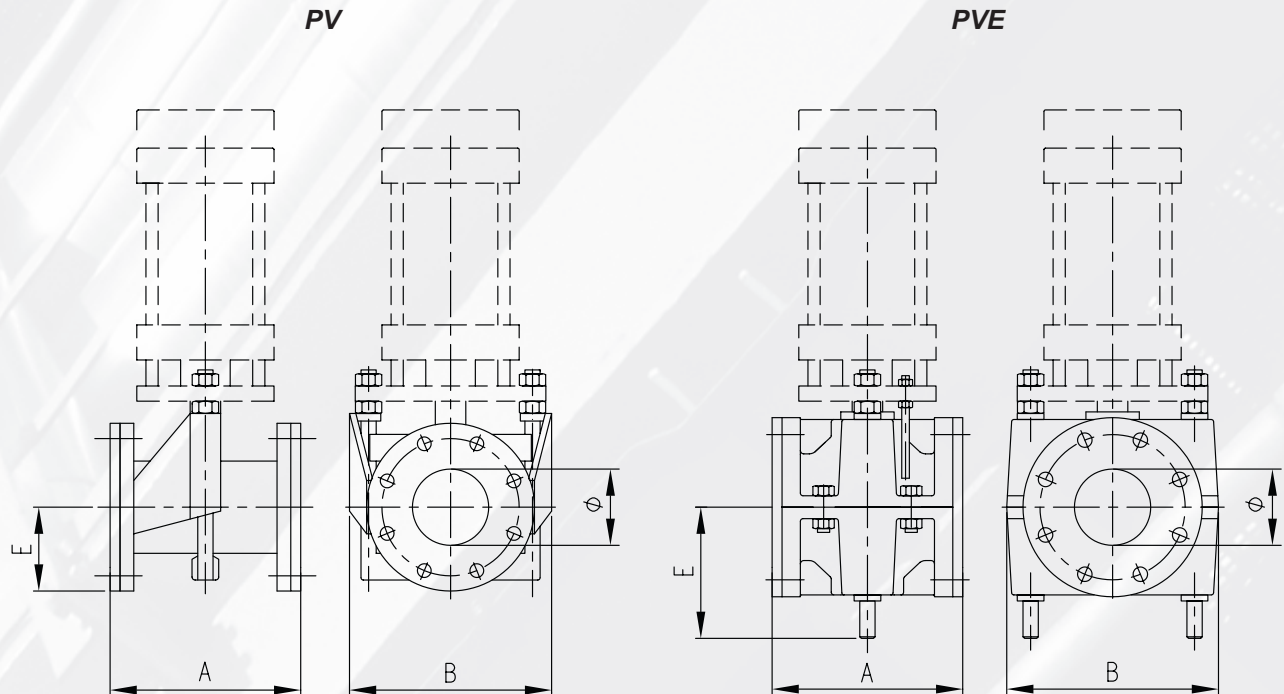

Weights are for body and sleeve *without actuator*.

SIZE Ø	PN (BAR)	A (MM)	B (MM)	E (MM)	WEIGHT FE (KG)	WEIGHT AL (KG)
PV 80	1 - 25	200	235	100	14	-
PV 100	1 - 25	250	265	110	16	-
PV 125	1 - 25	310	325	135	23	-
PV 150	1 - 16	375	381	143	36	-
PV 200	1 - 16	500	461	170	47	-
PV 250	1 - 10	625	545	210	85	-
PV 300	1 - 6	750	704	250	100	-
PVE 25	1 - 25	165	125	87	8	4
PVE 32	1 - 25	165	140	90	10	5
PVE 40	1 - 25	165	180	105	12	6
PVE 50	1 - 25	165	190	120	13	7
PVE 65	1 - 25	165	210	136	17	9
PVE 80	1 - 25	200	245	155	27	13
PVE 100	1 - 25	250	278	175	33	17
PVE 125	1 - 25	310	340	210	48	25
PVE 150	1 - 16	375	400	240	75	43
PVE 200	1 - 16	500	480	295	119	-
PVE 250	1 - 10	625	570	380	161	-
PVE 300	1 - 6	750	720	445	212	-

Dimensions subject to change without notice. Larger sizes and higher pressures also available. Complete dimensional drawings with selected actuator available upon request.



FOR YOUR LOCAL LAROX REPRESENTATIVE SEE

WWW.LAROX.FI/FLOWSYS/

LAROX
FLOWSYS

COMPANY PROFILE

THE SOLUTION YOU'VE BEEN LOOKING FOR

LAROX
FLOWSYS

MANUAL VALVES

THE SOLUTION YOU'VE BEEN LOOKING FOR

LAROX
FLOWSYS

LPP PUMP

THE SOLUTION YOU'VE BEEN LOOKING FOR

LAROX
FLOWSYS

LPP-D PUMP

THE SOLUTION YOU'VE BEEN LOOKING FOR

LAROX
FLOWSYS

VALVE SLEEVES

THE SOLUTION YOU'VE BEEN LOOKING FOR

LAROX
FLOWSYS

PVES VALVES

THE SOLUTION YOU'VE BEEN LOOKING FOR



TYPE APPROVAL
P-11460



ISO 9001

LAROX FLOWSYS OY • P.O. BOX 338 • FI-53101 LAPPEENRANTA, FINLAND • TEL. +358 201 113 311 • FAX +358 201 113 300
E-MAIL INFO@LAROX.FI • WWW.LAROX.FI