

NOTICE

THIS DRAWING IS THE PROPERTY OF QUALITROL COMPANY LLC AND IS LOANED ONLY ON THE CONDITION THAT IT WILL BE USED TO FACILITATE THE PURPOSE FOR WHICH INTENDED AND NOT BE REPRODUCED, COPIED OR OTHERWISE DISPOSED OF, AND IS NOT TO BE USED IN WHOLE OR PART FOR FURNISHING INFORMATION RELATIVE TO THE MAKING OF DRAWINGS, PARTS APPARATUS OR PARTS THEREOF, EXCEPT BY WRITTEN ORDER FROM QUALITROL COMPANY LLC.

MODEL NO. 104-683-03

CASE: CAST ALUMINUM WITH ASA #70 LIGHT GRAY
CASE IS VENTED AND MEETS REQUIREMENTS OF IP65.
BEZEL: ALUMINUM - REMOVABLE.

DIAL COLORS: BACKGROUND - BLACK
CHARACTERS - WHITE

POINTER COLOR: WHITE

MAX. INDICATING POINTER COLOR: RED

SWITCH SETTING INDICATOR COLOR: SILVER

LENS: POLYCARBONATE

SWITCH SETTING ADJUSTABILITY: 18°-162°C.

SWITCH DIFFERENTIAL: 7.5 °C ± 2.5 °C.

ACCURACY: ± 2% OF DIAL RANGE.

SWITCH RATING: UL/CSA RATING:

- 10 AMPS AND 1/3 HP @ 125, 250, VAC
- 1/2 AMP @ 125 VDC (NON-INDUCTIVE)
- 1/4 AMP @ 250 VDC (NON-INDUCTIVE)
- 4 AMPS @ 125 VAC "L" (LAMP LOAD)

DIELECTRIC STRENGTH: 1,500 VOLTS TO GROUND
FOR 60 SECONDS.

TO ADJUST SWITCH INDICATOR(S):

- A) REMOVE BEZEL AND LENS ASSEMBLY.
- B) LOOSEN SCREWS AND MOVE SWITCH SETTING INDICATOR TO DESIRED SETTING. RE-TIGHTEN SCREWS.
- C) REPLACE BEZEL AND LENS ASSEMBLY.

TO CHECK SWITCH OPERATION MANUALLY:

- A) REMOVE BEZEL AND LENS ASSEMBLY.
- B) TURN POINTER CLOCKWISE PAST THE SWITCH SETTING INDICATOR.
- C) SLOWLY RETURN THE POINTER TO ITS ORIGINAL POSITION.
- D) REPLACE BEZEL AND LENS ASSEMBLY.

CAUTION!! POINTER MUST NEVER BE
TURNED COUNTERCLOCKWISE.

**WIRING DIAGRAM
(ANSI)**

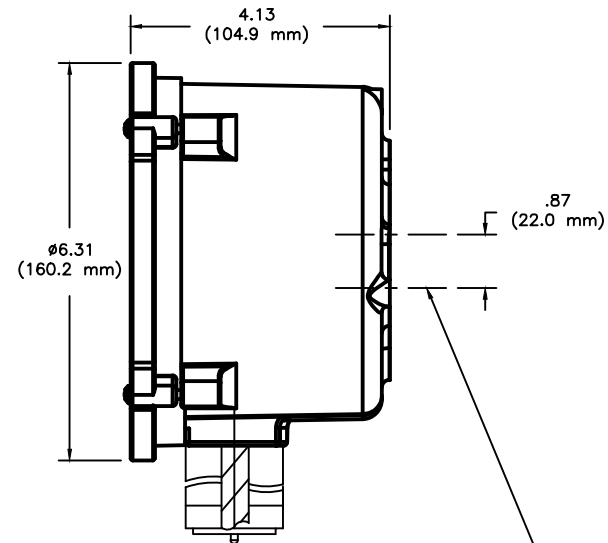
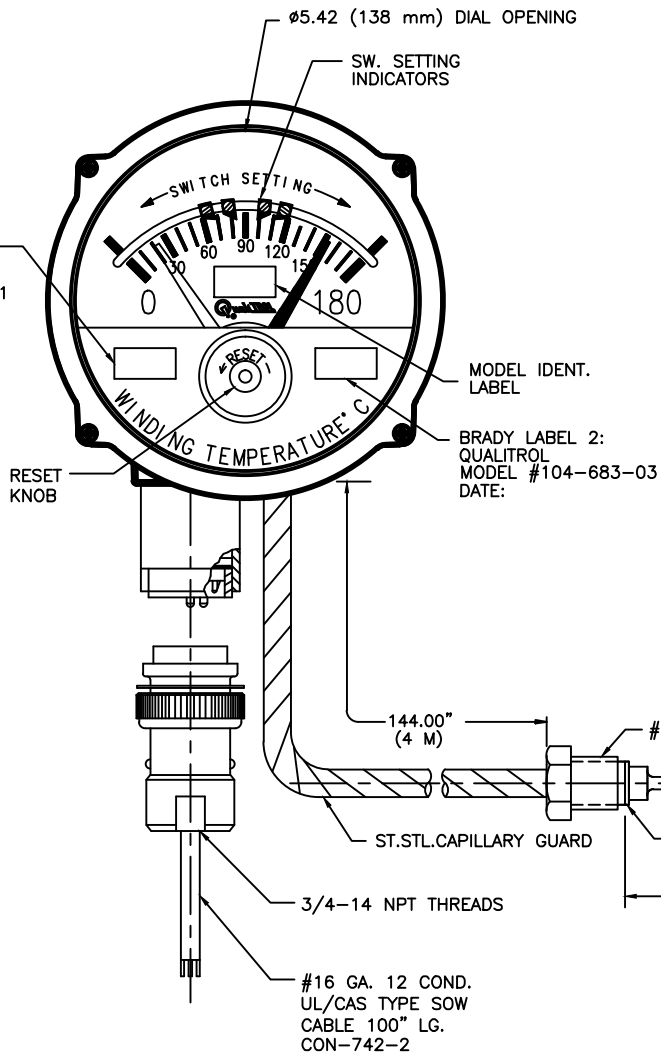
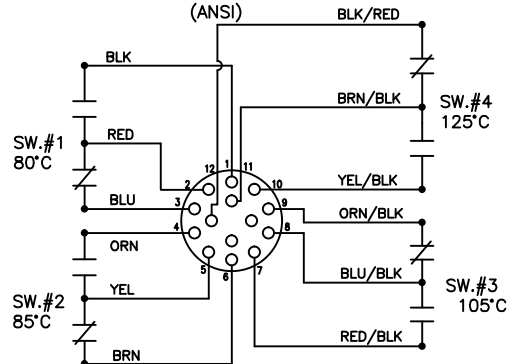

1/2-13 UNC-2B X .62 DP. MTG INSERT
LOCATED ON VERT.CENTER LINE OF UNIT.

SHOWN LOOKING AT MALE INSUL. ASSY. FROM OUTSIDE OF CASE.

-	4-20-16	UPDATED TO CASE/SCREW ON BEZEL DESIGN	34519
-	7-21-15	CHANGED CASE AND BEZEL TO NEW DESIGN	33833
-	10-21-05	ADDED CON-742-2 P/N CALLOUT	25414
LET	DATE	ALTERATION	C.N.

QUALITROL.

DIMENSIONS AND TOLERANCES IN
ACCORDANCE WITH ASME Y14.5M-1994

PH. (585) 586-1515
FAX (585) 377-0220

1385 FAIRPORT ROAD
FAIRPORT, NY 14450

FORM 0-473 REV. F 04/06/06

TITLE: 6" REMOTE MT. THERMO
(4 SWITCH)

MODEL NO. 104-683-03