

TYPE V

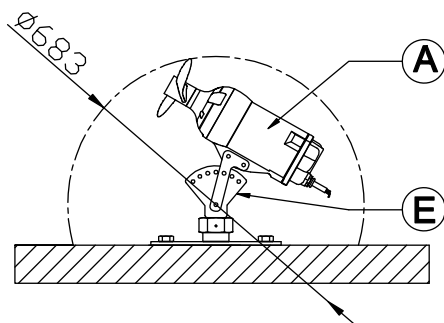
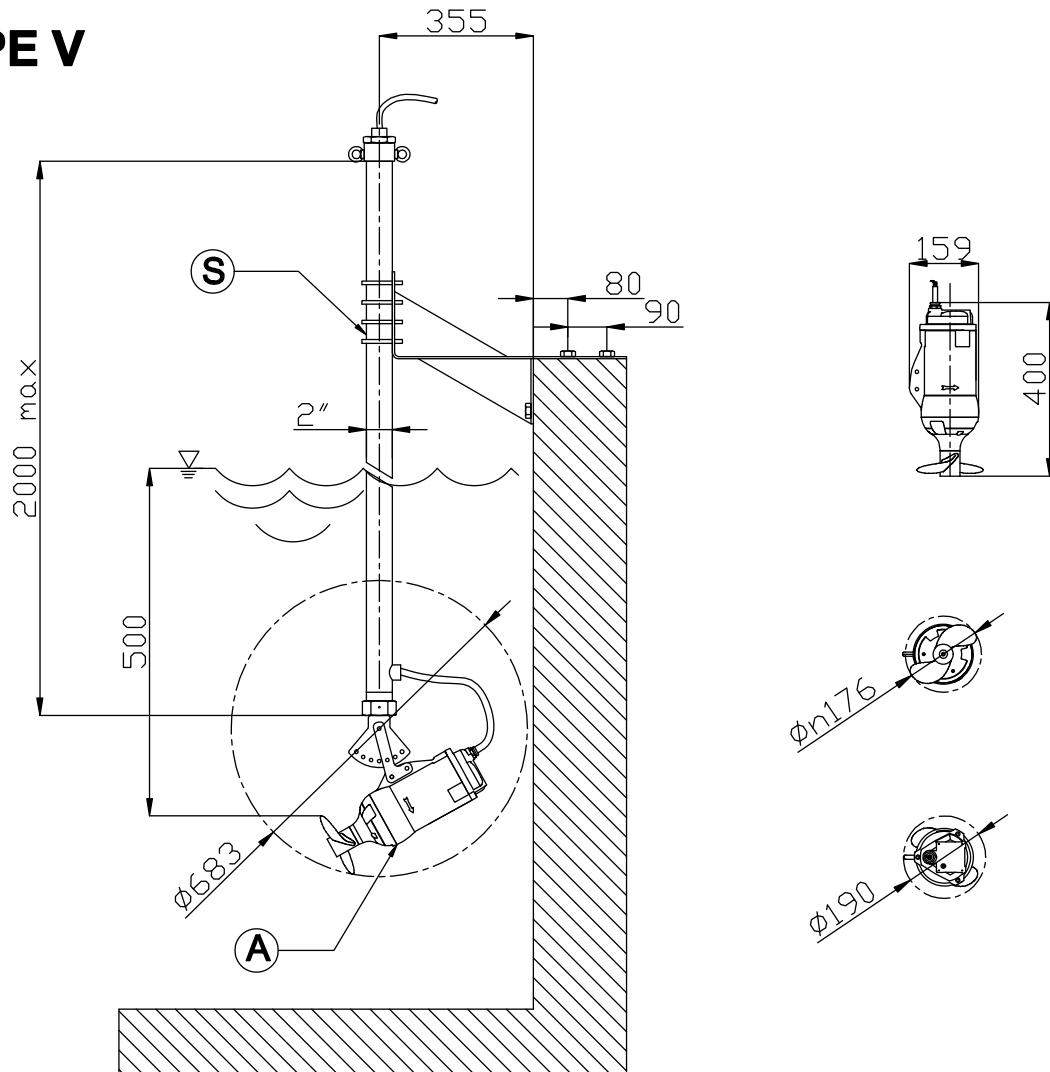

▽ LIVELLO MINIMO DI
SOMMERSIBILITA'
▽ MINIMUM
SUBMERSIBLE LEVEL

Pos.	Codice	Descrizione	Materiale	Peso Kg
Pos.	Code	Description	Material	Weight Kg
A	--	Miscelatore Mixer		-
E	SASGM16P02	Piastra di fissaggio Fixing base plate	AISI304 Acciaio S.Steel AISI304	8
S	SSM050-304P06	Struttura sostegno mixer Mixer's installation equipment	Acciaio AISI 304 S.Steel AISI 304	11