



ISO 9001:2015 by L.R.
PED DIR. 2014/68/UE by L.R.
ATEX DIR. 2014/34/UE by B.V.
FIRE SAFE EXECUTION by L.R.
ISO 15848 by TÜV (UP TO PN 63)
ANTISTATIC DEVICE by L.R.
FIRE SAFE TESTED ISO 10497 by L.R.
EAC CERTIFICATION by B.V.

TYPE
FS2
PN 40 ÷ 250

NORME E DIRETTIVE APPLICATE DISPONIBILI AL SEGUENTE LINK:
STANDARD AND DIRECTIVE APPLIED AVAILABLE AT FOLLOWING LINK:
http://www.adlerspa.com/pdf/NORME_ADLER.pdf

VALVOLE A SFERA "2 PEZZI" PASSAGGIO TOTALE

GAS ISO 7 - ANSI B1.20.1 NPT

ISO nbr° LRC 0160281 QMS issued by L.R.Q.A. PED nbr° COV 0212112/01 issued by L.R.V.
ATEX nbr° 40.2003.4392 issued by B.V. ISO 15848 nbr° I-148466/1-/2 issued by TÜV

On request
S.I.L. 3
According to IEC 61508

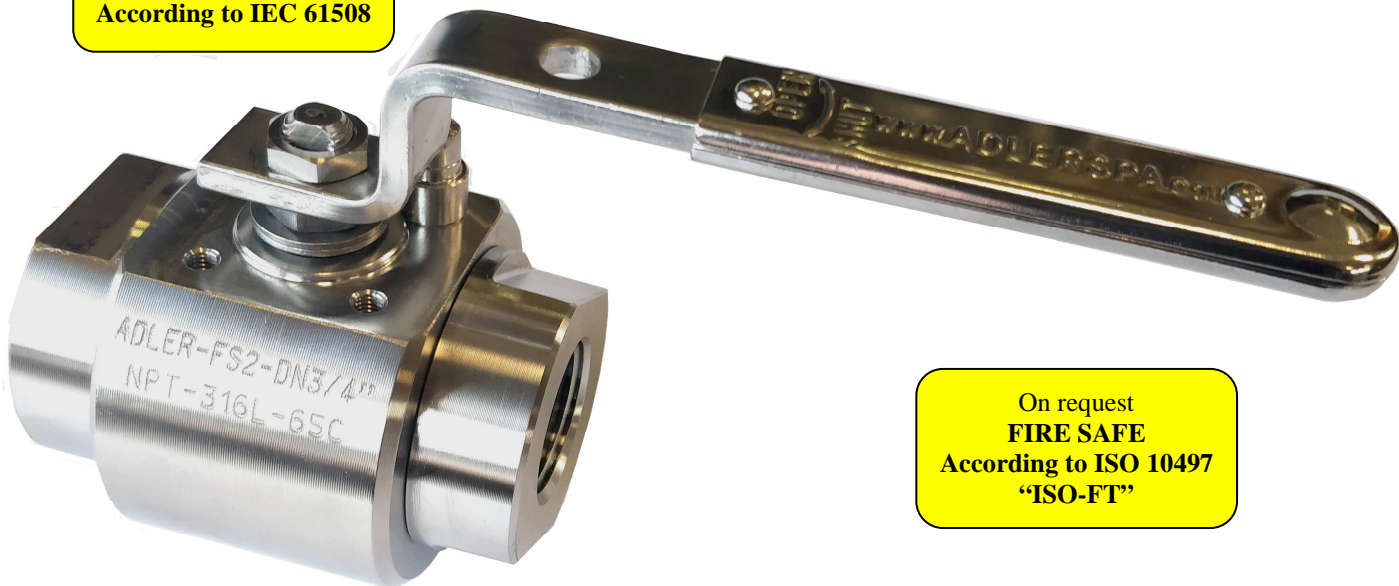

On request
FIRE SAFE
According to ISO 10497
"ISO-FT"

FULL BORE ACCORDING
TO ISO 14313

CONSTRUCTION ACCORDING TO:
BS EN 12516-2 - DIN 3202 M3
ISO 14313

BALL VALVES "2 PIECE" FULL BORE
ROBINETS A BOISSEAU SPHERIQUE
"2 PIECES" PASSAGE INTEGRAL
KUGELHÄHNE "2 TEILIG" VOLLER DURCHGANG

WEB SITE: WWW.ADLERSPA.COM



ISO 9001:2015 by L.R.
 PED DIR. 2014/68/UE by L.R.
 ATEX DIR. 2014/34/UE by B.V.
 FIRE SAFE EXECUTION by L.R.
 ISO 15848 by TÜV (UP TO PN 63)
 ANTISTATIC DEVICE by L.R.
 FIRE SAFE TESTED ISO 10497 by L.R.
 EAC CERTIFICATION by B.V.

TYPE
FS2
 PN 40 ÷ 250

VALVOLA A SFERA "2 PEZZI" PASSAGGIO TOTALE
BALL VALVES "2 PIECE" FULL BORE
ROBINETS A BOISSEAU SPHERIQUE "2 PIECES" PASSAGE INTEGRAL
KUGELHÄHNE "2 TEILIG" VOLLER DURCHGANG

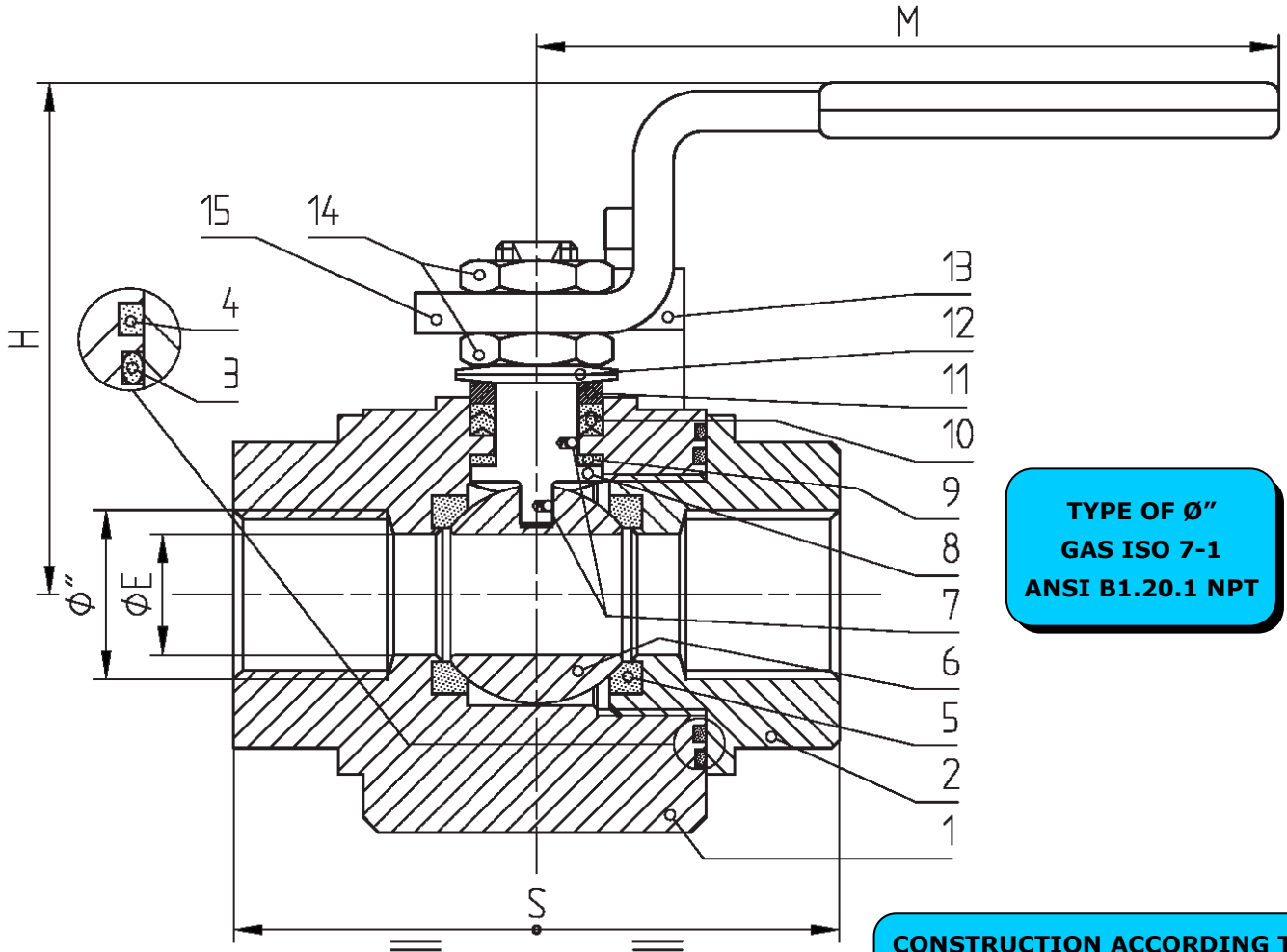

TYPE OF ϕ"
 GAS ISO 7-1
 ANSI B1.20.1 NPT

CONSTRUCTION ACCORDING TO:
 BS EN 12516-2 - ISO 14313
 EN 16722 M3 (ex DIN 3202)

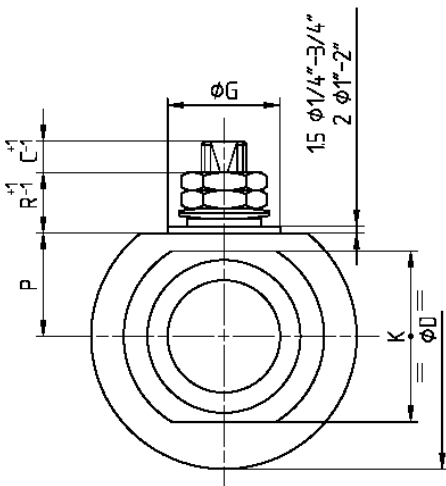

• ACCOPPIAMENTO VALVOLA
 ATTUATORE
 • CONNECTION VALVE
 ACTUATOR
 • ACCOUPLEMENT ROBINET-
 ACTIONNEUR
 • ZUSAMMENBAU KUGELHAHN
 ANTRIEB
ISO-5211

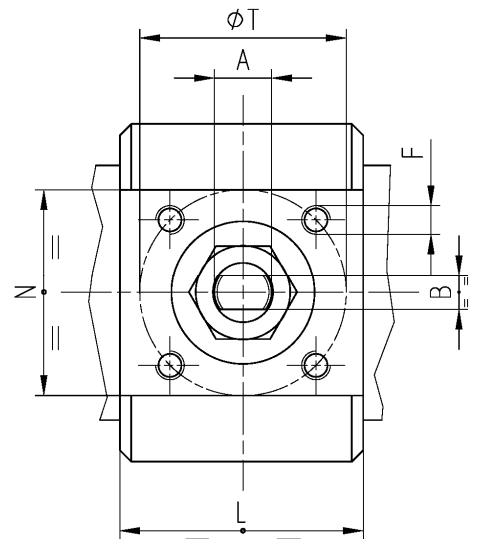



ISO 9001:2015 by L.R.
 PED DIR. 2014/68/UE by L.R.
 ATEX DIR. 2014/34/UE by B.V.
 FIRE SAFE EXECUTION by L.R.
 ISO 15848 by TÜV (UP TO PN 63)
 ANTISTATIC DEVICE by L.R.
 FIRE SAFE TESTED ISO 10497 by L.R.
 EAC CERTIFICATION by B.V.

TYPE
FS2
 PN 40 ÷ 250

N.	DESCRIZIONE DESCRIPTION DESCRIPTION BESCHREIBUNG	MATERIALI MATERIALS MATERIAUX WERKSTOFFE
1	CORPO BODY CORPS MITTE	ASTM A105 ASTM A479 304/304L ASTM A479 316/316L
2	GHIERA INSERT EMBOUT GEWINDED RUCKRING	ASTM A105 ASTM A479 304/304L ASTM A479 316/316L
3*	O'RING	FKM (VITON)
4*	ANELLO SEAL ANNEAU DICHTUNGSRING	P.T.F.E.
5*	SEDE RINFORZATA SEAT REINFORCED SIEGE RENFORCE SITZRING VERSTÄRKT	P.T.F.E. / 15% FIBERGLASS P.T.F.E. / STAINLESS STEEL
6	SFERA BALL BOULE KUGEL	ASTM A479 304/304L ASTM A351 CF8 ASTM A479 316/316L $\varnothing \leq 3/8"$ ASTM A351 CF8M
7	DISPOSITIVO ANTISTATICO ANTISTATIC DEVICE CONTACT ANTISTATIQUE ANTISTATIK VORRICHTUNG	ASTM A479 316/316L
8	STELO STEM TIGE SPINDEL	ASTM A479 304/304L ASTM A479 316/316L $\varnothing \leq 3/8"$

N.	DESCRIZIONE DESCRIPTION DESCRIPTION BESCHREIBUNG	MATERIALI MATERIALS MATERIAUX WERKSTOFFE
9*	BUSSOLA STEM SEAL JOINT TIGE UNTERE SPINDEL ABDICHTUNG	P.T.F.E.
10*	PACCO A "V" CHEVRON RINGS JOINT A "V" 3 FACHE DACHMANSCHETTE	P.T.F.E. / GRAFITE P.T.F.E. / GRAPHITE P.T.F.E. / GRAPHITE P.T.F.E. / GRAPHIT
11	PREMIBUSSOLA PRESSING BUSH PRESSE RONDELLE STOPFBUCHSDRUCKRING	ASTM A479 304
12	MOLLE A TAZZA SPRING WASHERS RONDELLES BELLEVILLE TELLERFEDERN	C72/50Cr V4 X5CrNi17.7 or X12CrNi17.7 ZINCATO - GALVANIZED - ZINGUE - VERZINKT ON REQUEST
13	VITE DI FERMO E FERMO PIN AND STOP PIN PLOT ET PLOT D'ARRET ANSCHLAGBOLZEN	UNI 3740 8.8 UNI 3951 A2-70 ZINCATO - GALVANIZED - ZINGUE - VERZINKT ON REQUEST
14	DADO - CONTRODADO NUT - LOCK NUT ECROU - CONTRE-ECROU MUTTER - KONTERMUTTER	UNI 3740 - 6S ASTM A479 304 ZINCATO - GALVANIZED ZINGUE - VERZINKT ON REQUEST
15	LEVA WRENCH LEVIER HANDHEBEL	AISI 1010 ASTM A479 304 ZINCATO/VERNICIATO GALVANIZED/PAINTED ZINGUE/PEINT VERZINKT/GEMALTEN ON REQUEST
16		

* RICAMBI CONSIGLIATI - RECOMMENDED SPARE PARTS - PIECES DE RECHANGE CONSEILLEES - ERSATZTEIL EMPFEHLUNG

DIMENSIONI - DIMENSION - DIMENSIONS - ABMESSUNGEN

Ø	1/4"	3/8"	1/2"	3/4"	1"	1 1/4"	1 1/2"	2"	2 1/2"	3"				
A	8	8	10	10	12	12	16	16	22	22				
B	5	5	6	6	8	8	10	10	14	14				
C	6	6	7	7	9	9	11	11	16	16				
D	49,5	49,5	59	64	74	80	99	119	169	186				
E	10	10	15	19	25	30	38	51	64	76				
F	M5	M5	M5	M5	M5	M5	M6	M6	M8	M8				
ISO	F03	F03	F03	F03	F03	F03	F05	F05	F07	F07				
G	25	25	25	25	25	25	35	35	55	55				
H	46	46	63	65	76	80	98	108	140	148				
K	30	30	38	42	50	55	70	85	120	130				
L	33	33	42	46	55	58	71	79	129	129				
M	120	120	145	145	185	185	280	280	370	370				
N	35	35	37	38	37	35	46	50	67	71				
P	17,7	17,7	23	25,3	32	36	44	54	77,5	86				
R	12	12	14	14	16	16	19	19	23,5	23,5				
S	50	60	75	80	90	110	120	140	185	205				
T	36	36	36	36	36	36	50	50	70	70				
PN	100	100	63	63	40	40	40	40	40	40	CLASS 800			
PN	250	250	250	250	250	160	160	160	160	160	CLASS 3000			
Kg	0.6	0.65	1.2	1.4	2.2	3.2	5.2	7.8	20	26				

A105
STANDARD
 ZINCATO
 GALVANIZED
 ZINGUE
 VERZINKT

- DATI E CARATTERISTICHE SOGGETTI A VARIAZIONI SENZA PREAVVISO
- SPECIFICATIONS SUBJECT TO MODIFICATIONS WITHOUT PRIOR NOTICE
- TOUS DROITS DE MODIFICATION RESERVES
- KONSTRUKTIONSÄNDERUNGEN VORBEHALTEN



ADLER SpA - BALL VALVES
 20010 S. STEFANO TICINO (MI) ITALY V.le BORLETTI, 14 Tel. +39/02974842.11 FAX +39/0297271698
 E-mail: adler@adlerspa.com <http://www.adlerspa.com>



ISO 9001:2015 by L.R.
 PED DIR. 2014/68/UE by L.R.
 ATEX DIR. 2014/34/UE by B.V.
 FIRE SAFE EXECUTION by L.R.
 ISO 15848 by TÜV (UP TO PN 63)
 ANTISTATIC DEVICE by L.R.
 FIRE SAFE TESTED ISO 10497 by L.R.
 EAC CERTIFICATION by B.V.

TYPE
FS2
 PN 40 ÷ 250

• ESECUZIONI • EXECUTIONS • EXECUTIONS • AUSFÜHRUNGEN



EXECUTION 4- 12

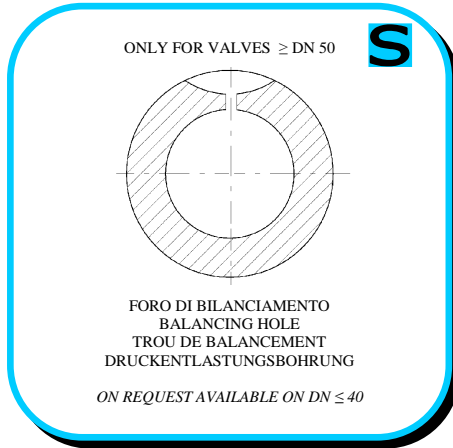

EXECUTION 6 - 16

S STANDARD

O OPTIONAL

1 PN 160 ÷ 250 **S**

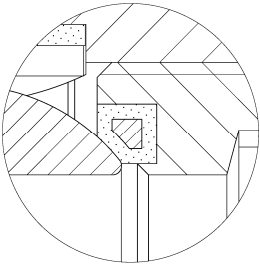

-SEDI ANIMA METALLICA -SEATS WITH METAL CORE
 -SIEGES AVEC AME METALLIQUE -SITZE MIT METALLKERN

2 PN 40 ÷ 100 **O**

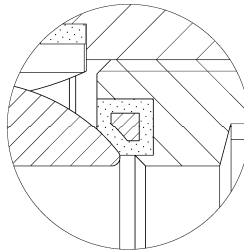

-SEDI ANIMA METALLICA -SEATS WITH METAL CORE
 -SIEGES AVEC AME METALLIQUE -SITZE MIT METALLKERN



4 **S**

-STELO ANTI ESPULSIONE -ANTI BLOW OUT STEM
 -TIGE ANTIEXPULSION -AUSBLASGESICHERETE WELLE

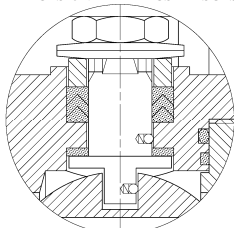

-PACCO A "V" -CHEVRON RINGS
 -JOINT A "V" -3 FACHE DACHMANSCHETE
 ANTISTATIC DEVICE ANTISTATIK VORRICHTUNG
 BS 5146

5 DN 1/4" ÷ 1 1/4" **O**

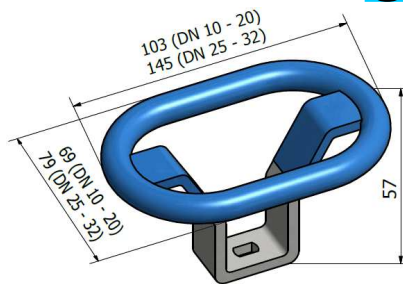

-MANIGLIA OVALE - OVAL HANDLE
 -LEVIER OVAL -HANDHEBEL IM OVALFORM

6 **BREVETTO - PATENTED** **O**
 00219688

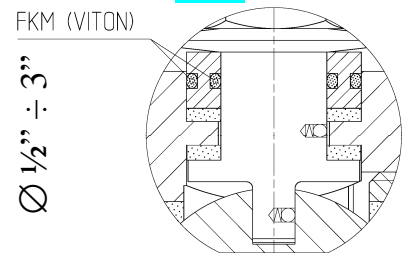

- "O" RING STELO "O" RING ON STEM
 -TIGE AVEC "O" RING
 -"O" RING IM SPINDELBEREICH

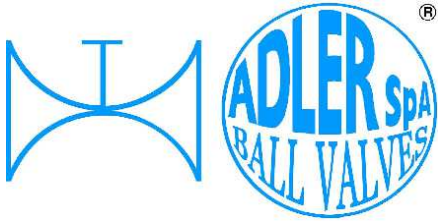

ISO 9001:2015 by L.R.
 PED DIR. 2014/68/UE by L.R.
 ATEX DIR. 2014/34/UE by B.V.
 FIRE SAFE EXECUTION by L.R.
 ISO 15848 by TÜV (UP TO PN 63)
 ANTISTATIC DEVICE by L.R.
 FIRE SAFE TESTED ISO 10497 by L.R.
 EAC CERTIFICATION by B.V.

TYPE
FS2
 PN 40 ÷ 250

7

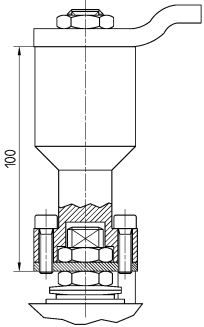

-PROLUNGA STELO -STEM EXTENSION
 -TIGE PROLONGEE -SPINDELVERLÄNGERUNG

8

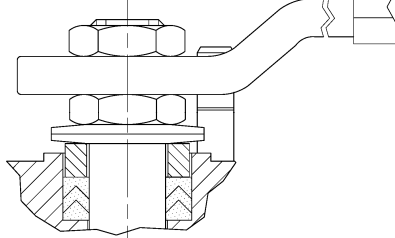

-PARTICOLARI INOX
 -STAINLESS STEEL DETAILS
 -ACCESSOIRES EN INOX
 -EDELSTAHLTEILE

9

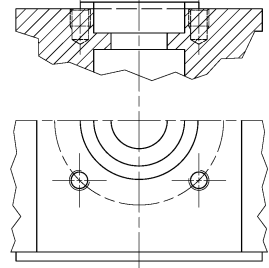

-ATTACCO "ISO" -"ISO" CONNECTIONS
 -SYSTEM "ISO" -ANSCHLUSS "ISO"

ADLER

UNA GAMMA COMPLETA
 PRIVILEGIANDO LA QUALITA'

A COMPLETE RANGE PRIVILEGING
 THE QUALITY



12

FIRE SAFE
 ISO 10497 "ISO-FT"
 (BS 6755 / API 607)



13

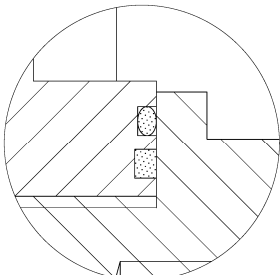

-DOPPIA TENUTA -DOUBLE SEALS
 -DOUBLE ETANCHEITE -DOPPELTE ABDICHTUNG

14

VEDERE / SEE ANSI B16.34

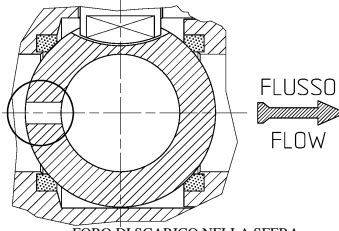

-FORO DI SCARICO NELLA SFERA
 -OVERPRESSURE HOLE INTO BALL
 -TROU DECOMPRESSION DANS LA BOULE
 -ENTLASTUNGSBOHRUNG IN DER KUGEL
 VALVOLA MONO DIREZIONALE
 MONO-DIRECTIONAL VALVE

15

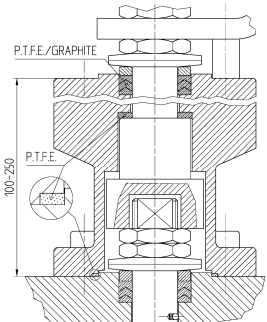

-SERVIZIO CRIOGENICO - CRYOGENIC SERVICE
 -SERVICE CRYOGENIQUE
 -TIEFTEMPORATUR SERVICE

PED CERTIFICATION



ADLER

UNA GAMMA COMPLETA
 PRIVILEGIANDO LA QUALITA'

A COMPLETE RANGE PRIVILEGING
 THE QUALITY



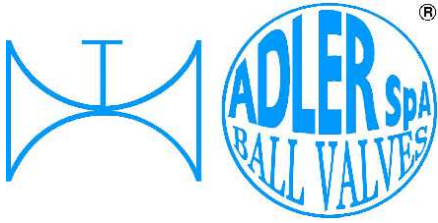

ISO 9001:2015 by L.R.
 PED DIR. 2014/68/UE by L.R.
 ATEX DIR. 2014/34/UE by B.V.
 FIRE SAFE EXECUTION by L.R.
 ISO 15848 by TÜV (UP TO PN 63)
 ANTISTATIC DEVICE by L.R.
 FIRE SAFE TESTED ISO 10497 by L.R.
 EAC CERTIFICATION by B.V.

TYPE
FS2
 PN 40 ÷ 250

CARATTERISTICHE DEL FILETTO - THREAD FEATURES - FILETAGE CARACTÉRISTIQUES - GEWINDE KENNDATEN

IN ACCORDANCE TO
 ISO 7-1 – 1994

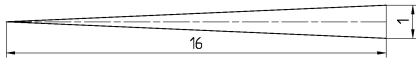

H= 0.960 237 P
 h= 0.640 327 P
 r= 0.137 278 P

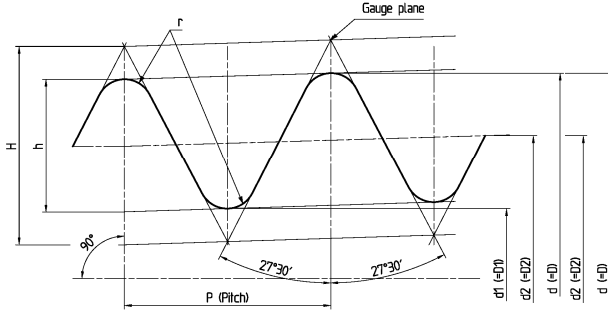

1	2	3	4	5			6					7		8			9			18	19	20
				Diameters of gauges plane			Gauges length (external threads)					Tolerance on position of gauge plan on internal thread		Length of useful external thread not less than			Fitting allowance					
				Major d	Pitch d ₂	Minor d ₁	Nominal	Tolerance ±t/2		Max.	Min.	Tolerance ±t/2		For nominal gauge length	For maximum gauge length	For minimum gauge length						
				2)	Turns of thread			2)	Turns of thread				2)	Turns of thread	Diameter tolerance on parallel internal threads							
1/4	19	1,337	0,856	13,15	12,30	11,44	6	1,3	1	7,3	4,7	1,7	1 1/4	9,7	11	8,4	3,7	2 3/4	±0,104			
3/8	19	1,337	0,856	16,66	15,80	14,95	6,4	1,3	1	7,7	5,1	1,7	1 1/4	10,1	11,4	8,8	3,7	2 3/4	±0,104			
1/2	14	1,814	1,162	20,95	19,79	18,63	8,2	1,8	1	10	6,4	2,3	1 1/4	13,2	15	11,4	5	2 3/4	±0,142			
3/4	14	1,814	1,162	26,44	25,27	24,11	9,5	1,8	1	11,3	7,7	2,3	1 1/4	14,5	16,3	12,7	5	2 3/4	±0,142			
1	11	2,309	1,479	33,24	31,77	30,29	10,4	2,3	1	12,7	8,1	2,9	1 1/4	16,8	19,1	14,5	6,4	2 3/4	±0,180			
1 1/4	11	2,309	1,479	41,91	40,43	38,95	12,7	2,3	1	15	10,4	2,9	1 1/4	19,1	21,4	16,8	6,4	2 3/4	±0,180			
1 1/2	11	2,309	1,479	47,80	46,32	44,84	12,7	2,3	1	15	10,4	2,9	1 1/4	19,1	21,4	16,8	6,4	2 3/4	±0,180			
2	11	2,309	1,479	59,61	58,13	56,65	15,9	2,3	1	18,2	13,6	2,9	1 1/4	23,4	25,7	21,1	7,5	3 1/4	±0,180			

IN ACCORDANCE TO
 ANSI B1.20.1 – 1983

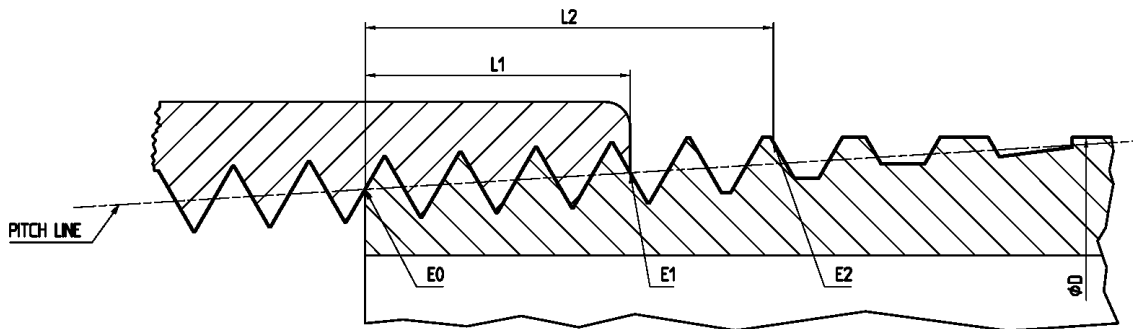

1	2	3	4	5	6			7			9	10	11				
					Nominal Pipe Size	O.D. of Pipe (D)	Threads/in ch (n)	Pitch of threads (P)	Pitch diam. at beginning of external thread (E ₀)	Handtight engagement				Effective thread, external			
										Length ² (L ₁)				Diam. ³ (E ₁)	Length ⁴ (L ₂)		Diam. ⁵ (E ₂)
					inch	threads	inch	threads									
1/4	0,540	18	0,05556	0,47739	0,2278	4,1	0,49163	0,4018	723	0,50250							
3/8	0,675	18	0,05556	0,61201	0,240	4,32	0,32701	0,4078	734	0,63750							
1/2	0,840	14	0,07143	0,75843	0,320	4,48	0,77843	0,5337	747	0,79179							
3/4	1,050	14	0,07143	0,96768	0,339	4,75	0,98887	0,5457	764	1,00179							
1	1,315	11,5	0,0896	1,21363	0,400	4,6	1,23863	0,6828	785	1,25630							
1 1/4	1,660	11,5	0,0896	1,55713	0,420	4,83	1,58338	0,7068	813	1,60130							
1 1/2	1,900	11,5	0,0896	1,79609	0,420	4,83	1,82237	0,7235	832	1,84130							
2	2,375	11,5	0,0896	2,26902	0,436	5,01	2,29627	0,7565	870	2,31630							