



240/12

Stirnradflaschenzug als Einschienenfahrwerk/ Spur Gear Hoist combined with monorail trolley/ Palan-Chariot combiné

ISO 9001
certified company

PROFESSIONAL LINE

HR - mit Rollfahrwerk / with push travel trolley / avec chariot à pousser

HH - mit Haspelfahrwerk / with hand geared trolley / avec chariot à avance par chaîne



Mit Stirnradflaschenzug Figur 8/12

Incorporating Spur Gear Hoist Type 8/12

Avec palan manuel Série 8/12



Laufrollen in wartungsfreien Kugellagern

Trolley wheels with maintenance-free ball bearings

Galets avec roulement à billes sans entretien



Last- und Handketten verzinkt, Lastkette nach EN 818-7-T

Zinc plated load and hand chains, load chain acc. to EN 818-7-T

Chaînes zinguées, chaîne de charge suivant EN 818-7-T



Deutsche Herstellung

Manufactured in Germany

Fabrication Européenne



Geräteschutz durch Rutschkupplung
Hoist protection by slipping clutch
Protection de l'appareil par
accouplement à friction



auf Anfrage
on request
sur demande

Tragfähigkeit/ Kettenstränge	Last- kette	Flanschbreite von - bis bei Lastbolzen		Hub bei Abhaspelung v. 30 m Kette	Handkraft bei Nennlast zum hand chain pull for effort à chaîne de manoeuvre		Gewicht Weight Poids	
		Flange width from - to for load bar size			Heben lifting levage ca./approx. /env. daN (1)	Fahren travel translation ca./approx. /env. daN (2)	bei 3 m	je m
		Largeur de fer de - à pour traverse					Laufbahnhöhe	Mehrhub
Capacity/ Chain falls	Load chain			Lift at 30 m hand chain path			at 3 m track height	per m add. lift
Capacité/ Brins de chaîne	Chaîne de charge			Levage par deroulem. de 30 m de chaîne de manoeuvre			pour 3 m de suspension ca./approx./env. kg	par m sup. de levée ca./approx./env. kg
kg	mm	1 N mm	2 N mm	mm				
500 / 1	5 x 15	50 - 146	147 - 302	930	26	6,5	19,2	2,8
1000 / 1	6 x 18	50 - 179	180 - 310	560	27	10	25,5	3
1500 / 1	8 x 24	66 - 185	186 - 310	520	38	11	47	3,6
2000 / 1	8 x 24	66 - 185	186 - 310	430	35	15	47	3,6
3000 / 2	8 x 24	74 - 196	197 - 310	265	39	11	71	5
5000 / 2	10 x 30	74 - 192	193 - 310	165	42	17	91	6,6
10000 / 4	10 x 30	119 - 215	216 - 312	82	45	21	206	11

(1) Handkette Heben/ hand chain for lifting/ chaîne de manoeuvre levée = 5 x 23,8 mm

(2) Handkette Fahren/ hand chain for travel/ chaîne de manoeuvre, translation = 5 x 25 mm





240/12

Stirnradflaschenzug als Einschienenfahrwerk/
Spur Gear Hoist combined with monorail trolley/ Palan-Chariot combiné

ISO 9001
certified company

PROFESSIONAL LINE

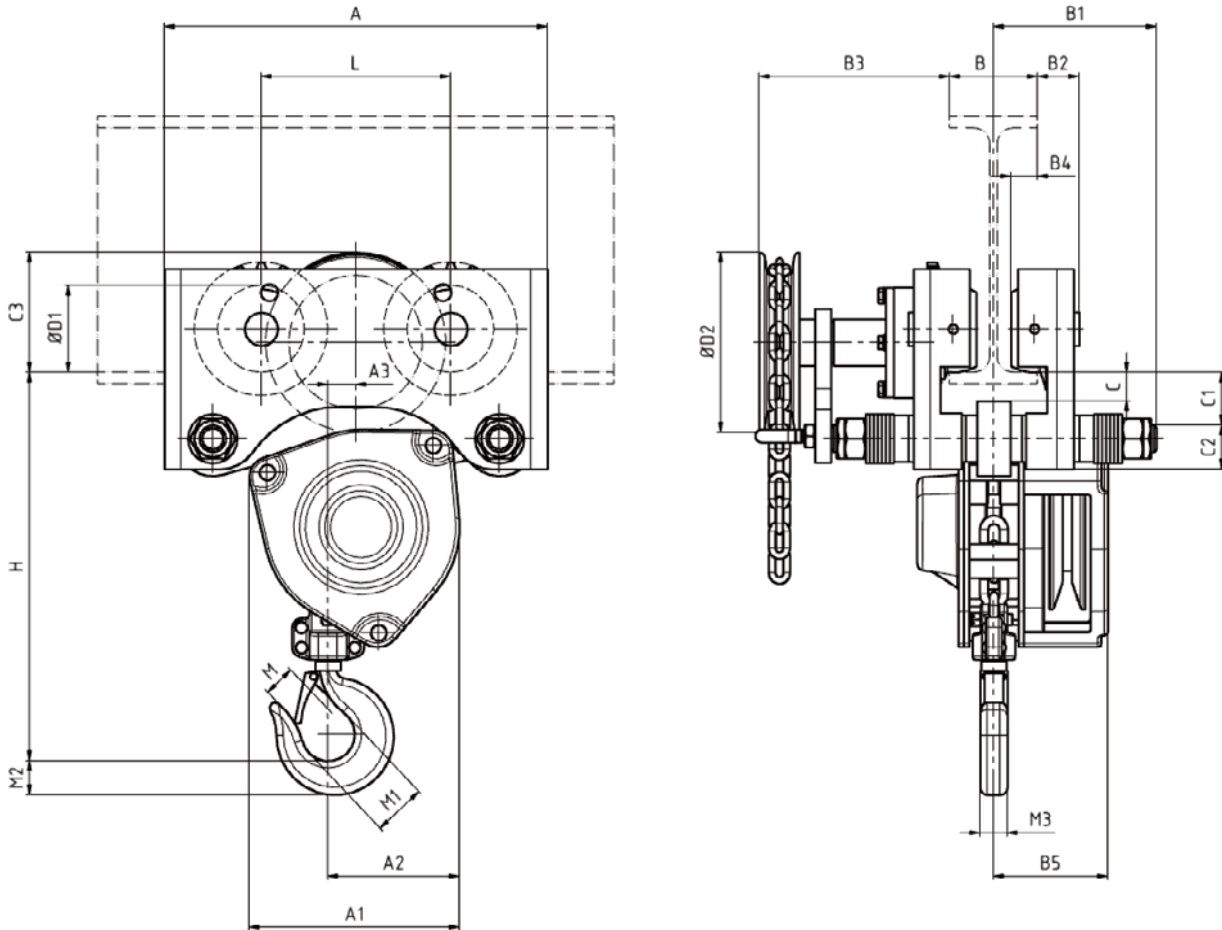

Tragfähigkeit/ Kettenstränge	Hauptabmessungen in mm																						
	Main dimensions in mm																						
	Dimensions principales en mm																						
	Capacity/ Chain falls Capacité/ Brins de chaîne kg																						
	A	A1	A2	A3	B1 bei Lastbolzengr. at load bar size pour traverse		B2	B3	B4	B5	B6	C	C1	C2	C3	D1	D2	H	L	M	M1	M2	M3
500 / 1	234	123	76	13	1N	2N	24	99	18	72	124	25	36	29	70	50	135	260	93	21	31	17	12
1000 / 1	287	148	87	13	151	216	31	143	20	75	134	22	38	35	90	65	135	290	142	27	38	21	17
1500 / 1	350	165	104	23	166	228	40	149	23	83	150	29	49	50	107	85	135	345	172	28	39	26	19
2000 / 1	350	175	105	20	166	228	40	149	23	84	156	29	49	50	107	85	135	370	172	30	46	29	22
3000 / 2	428	174	146	62	182	243	46	152	26	83	150	31	51	63	149	120	135	420	209	36	50	36	28
5000 / 2	492	206	183	54	190	258	53	286	28	97	179	33	64	65	162	120	195	600	223	42	59	44	36
10000 / 4	650	219	272	40	242	291	62	246	37	82	179	41	63	84	185	150	270	630	253	55	83	61	45

