

Screw pumps – PDA series with valve

For hydraulic oils, lubricating oils
 Admissible delivery pressure 10 bar
 Standard valve setting 6 bar

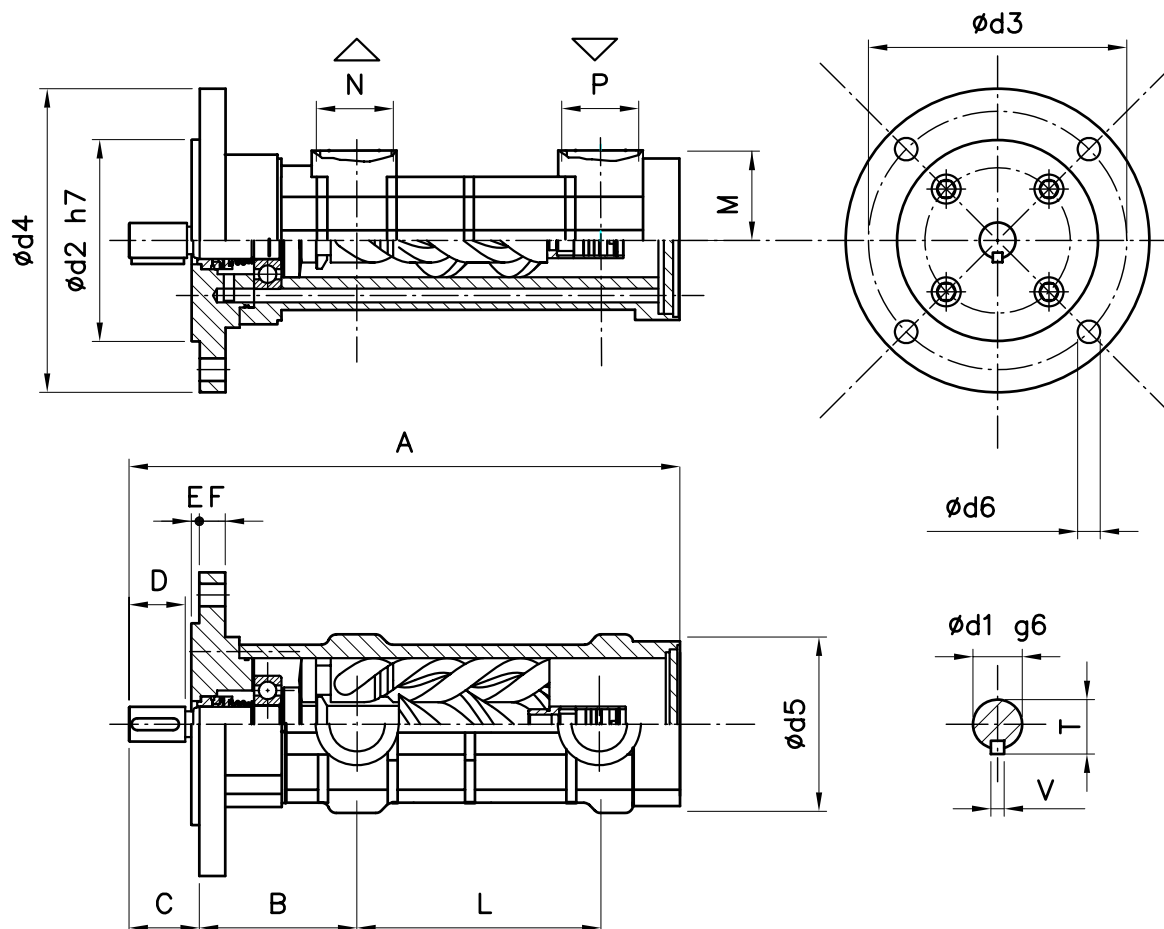

NF - STE - PDA - GB - 02.07 - 2

Dimensional chart (mm)

SIZE	A	B	C	D	E	F	L	M	N	P	T	V	d1	d2	d3	d4	d5	d6
PDA029#2..01.	286	82	42	37	5	14	122	44	GAS		21,5	6	19	100	125	150	95	11
PDA032#2..01.																		
PDA040#2..01.	307	82	42	37	5	14	140	48	1¼"	1¼"	21,5	6	19	100	125	150	95	11

SEIM srl
 Via A. Volta 17
 20090 Cusago (MI) ITALY
 Tel. (+39) 02.90.39.21.1
 Fax (+39) 02.90.39.21.41
 e-mail: seim@seim.it

www.seim.it

SEIM reserves the right to introduce dimensional changes or variation to the products of this technical data