

S-SERIES

Translating Screw Jack 25kN

Performance

Screw Jack Model ⁴		S-025		
Capacity	kN	25		
Lead Screw ¹	Diameter (mm)	30		
	Lead (mm)	6	12	
Gear Ratios	Option 1	6:1		
	Option 2	24:1		
	Option 3	8:1 (AOR)		
4 x Turns of worm for travel of lead screw	Option 1	4mm	8mm	
	Option 2	1mm	2mm	
	Option 3	3mm	6mm	
Maximum Input Power (kW)	Option 1	1.5		
	Option 2	0.375		
	Option 3	1.5		
Start up torque at full load (Nm) ²	Option 1	19	26	
	Option 2	8	11	
	Option 3	15	20	
Maximum Through Torque (Nm) ⁷	Option 1	59.4		
	Option 2	26.1		
	Option 3	59.4		
Static Efficiency ³	Option 1	0.209	0.314	
	Option 2	0.121	0.183	
	Option 3	0.194	0.293	
Dynamic Efficiency ³	Option 1	50rpm	0.262	0.379
	Option 1	750rpm	0.299	0.434
	Option 1	1500rpm*	0.309	0.448
	Option 2	50rpm	0.164	0.238
	Option 2	750rpm	0.220	0.320
	Option 2	1500rpm*	0.239	0.347
	Option 3	50rpm	0.247	0.358
	Option 3	750rpm	0.288	0.418
	Option 3	1500rpm*	0.301	0.436
Maximum Input Speed (rpm)	-	3000		
Gear Case Material	-	SG Iron		
Weight (kg) – stroke = 150mm	ST025	13.8		
	SR025	15.0		
Weight (kg) – per extra 25mm	SR025	0.16		
	ST025	0.11		

ST025 Closed Height

	Threaded End	Top Plate	Clevis End	Fork End	Rod End
Closed Height 'C'	157	157	182	207	204
Stroke (mm)	With Bellows Boots (B)				
0 - 300	157	157	182	207	204
301 - 600	171	171	196	221	218
601 - 1050	189	189	214	239	236
1051 - 1500	208	208	233	258	255
1501 - 1800	228	228	253	278	275

ST025 Stop Nut



Stop nut provides a full power mechanical stop at the end of the lead screw. To be used as a safety feature in emergency conditions.

SN = Stroke + 21mm

ST025

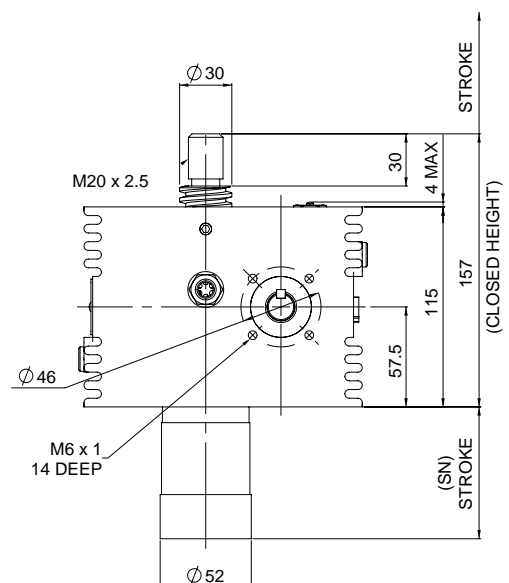
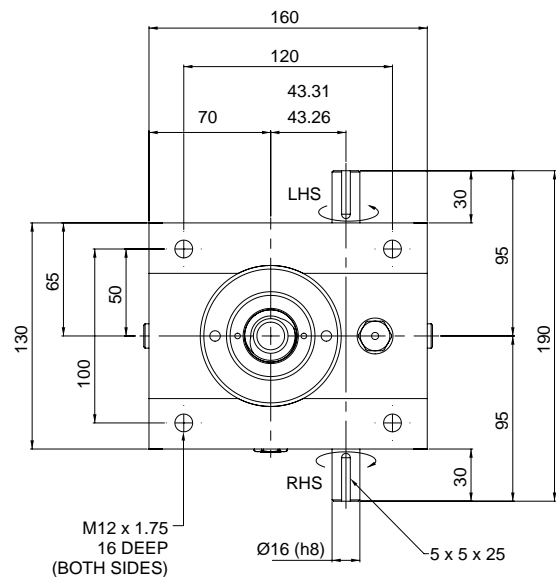

Note:

1. All dimension in millimetres unless otherwise stated.
2. Designs subject to change without notice.

S-SERIES

Rotating Screw Jack 25kN

SR025

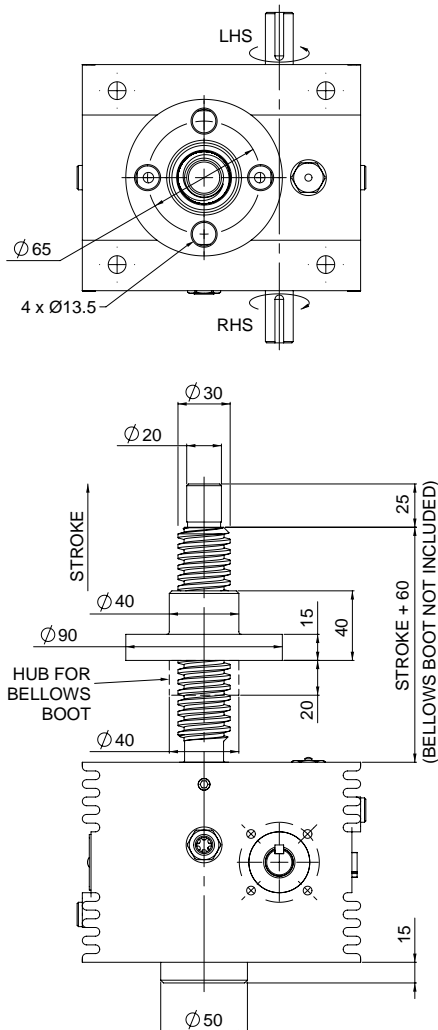

Column Strength

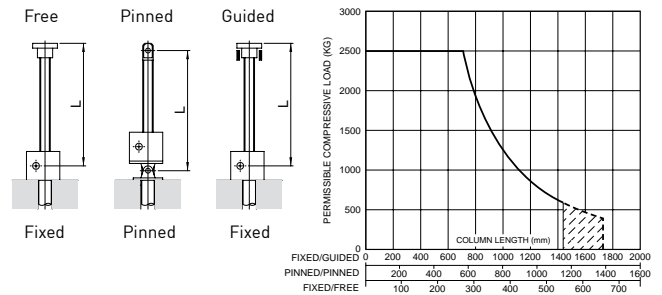

Critical Screw Speed

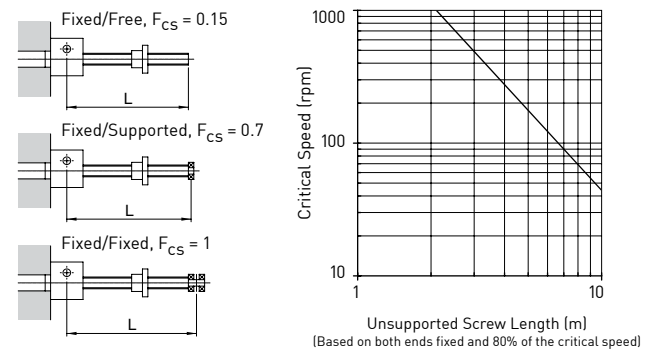

Bellows Boot

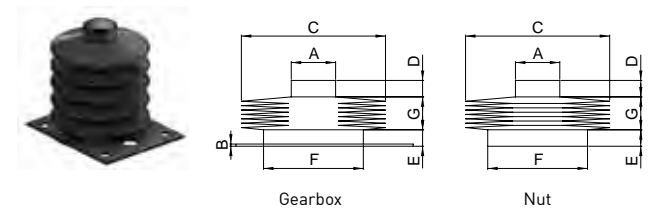

	ØA	B	ØC	D	E	ØF
ST025	40	2	130	10	10	45
SR025	40	2	130	10	15	40

Stroke	1 - 300	301 - 600	601 - 1050	1051 - 1500	1501 - 1800
G	14	28	46	65	85*

*control tapes fitted ØC=150

Accessories & Options

