



PRODUCT SPECIFICATION

VISIBLE EMISSION MONITOR
MODEL 252

GENERAL DESCRIPTION

Skil Emission Monitors are designed to measure dust and smoke discharged from Furnaces, Incinerators, Boilers and industrial plant. Satisfying legal requirements to monitor smoke and particulate emissions into the atmosphere.

The Model 252 Visible Emission Monitor may be used to continually monitor and display optical density or opacity, and will also display particulate emissions when calibrated on the ISO-kinetic sampling principle as described in BS893 and BS3405.

The equipment comprises a digital indicator control unit suitable for panel mounting, transmitter and receiver units, complete with extension tubes for mounting to the flue or stack.

The Monitor can also be used to measure other opaque fluids, such as fume within tunnels, vapour, fog and dust discharged from extractors and machinery.

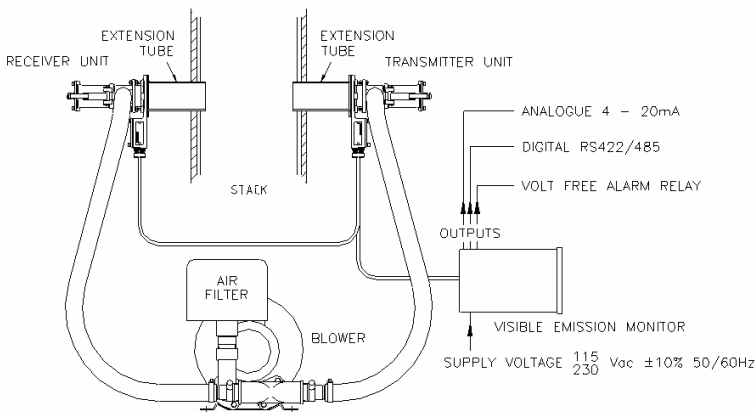

PRINCIPLE OF OPERATION

A visible beam of light is projected from the transmitter unit across the smoke path and onto a solid state sensor within the receiver unit. The light received varies as particles passing through the light beam absorb and scatter the light falling on the sensor. A sensor within the transmitter unit measures the light leaving the transmitter unit. The signal is received by a micro-processor based control unit, where the effects of ambient light are subtracted. The ratio of the resultant signal provide a stable drift free measurement of the light beam strength. Additional calculations are completed within the control unit to provide a direct reading of particulates or dust density ($MG M^3$).

INDICATOR CONTROL UNIT

The unit provides a large bright four-digit selectable display of:-
Optical density 0-999
Particle density 0-999 mg/m^3
Opacity 0-100%

Fitted with front of panel key-board control of zero setting, alarm set point and alarm test and mute. All calibration and commissioning adjustments from front panel with menu system and pin tamper protection. Multiple outputs available including analogue 4-20mA, digital RS422/RS485 interface continuous data stream giving current display in ASCII format at 9600 baud.

The control unit is housed in a DIN 43700 case suitable for panel mounting complete with rear terminal connections. Time averaging facility available and adjustable between 1 and 99 seconds to overcome stack emission fluctuations.

INDICATOR CONTROL UNIT DIMENSIONS

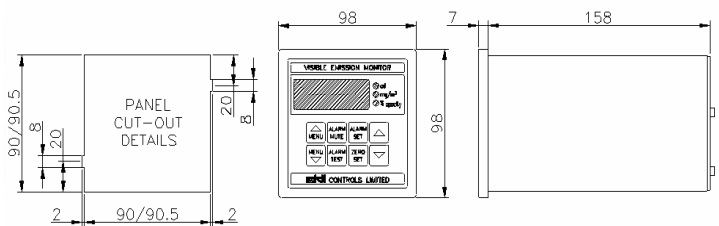

TRANSMITTER/RECEIVER STACK UNITS

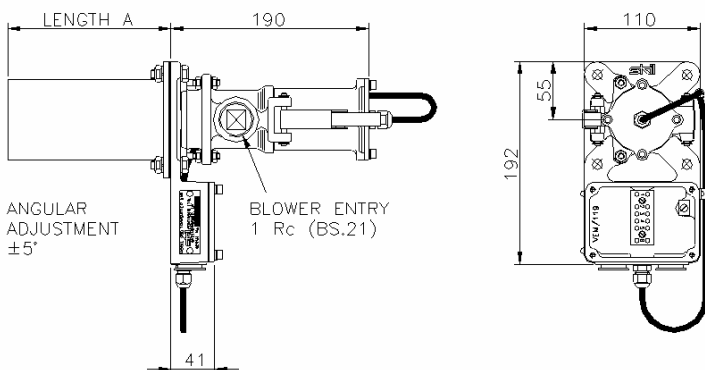

TRANSMITTER/RECEIVER STACK UNITS

The hermetically sealed transmitter and receiver units can be fitted to flanged extension tubes. The solid state opto-electronic devices are sealed within the units.

Quick release over centre fasteners are used for easy lens cleaning. Air input ports are available for the connection of an air blower unit recommended when measuring under positive pressure flue conditions.

BLOWER UNIT

The Blower Unit with air filter, complete with the necessary flexible hose and couplings, is available, to maintain a stable reading and reduces lens cleaning maintenance.

ELECTRONIC STACK UNIT ALIGNMENT AID

Skil Service staff carry a purpose-built electronic alignment unit, which when fitted to a standard digital multi-meter, can be used to align precisely the transmitter and receiver for optimum performance.

SPECIFICATION

Control Unit

Enclosure: DIN43700 case, 96 x 96 x 163
 Supply: Voltage Factory set to 115 or 230V ± 10% 50/60Hz ac
 Power Consumption: 6VA
 Display: 4 character red LED display, 14.2mm high
 Display modes: Selectable, one of three modes:
 Optical density 0 - 0.999 (displayed as 0 - 999)
 Particle density 0 - 999mg/m³
 Opacity 0 - 100%
 Stability: Typically better than ± 1% opacity or equivalent
 Ambient temperature: 0 to 50°C (32 to 122°F)
 Outputs: Alarm relay output top switch powered warning device. Continuously variable setpoint, adjustable in any display mode. Manual remote or automatic resets. Relay contacts factory-set to normally-open or normally-closed operation. Contacts rated at 2 amp 250V ac resistive. Alarm condition indicated by flashing display.
 Analogue: 4-20mA with independent drive selection from optical density, particle density or opacity. Maximum series impedance 600 ohms.
 Digital: RS422/RS485 interface. Continuous data stream giving current display reading in ASCII format at 9600 baud.
 Adjustments: All calibration and commissioning adjustments from front panel with menu system and PIN tamper protection.
 Auxiliary output: Second 4-20mA output available on a separate plug-in PCB Independent drive selection from optical density, particle density or opacity. Maximum series impedance 600 ohms.

Transmitter/Receiver Units

Throw limits: 0.3 to 6 metres
 Ambient temperature: -10 to +60°C (14 to 140°F)
 Emissions temperature: 850°C maximum
 Maximum cable length: 100m from panel unit
 Cable type: 6 core screened
 Opto-devices: Solid-state emitter and sensors
 Operating voltage: 5V maximum
 Mounting: Mount onto 76mm flanged extension tubes
 Extension tubes:
 Flange Qty. 4 mounting holes Ø9mm on 1209mm PCD
 Tube: 76mm (3") OD
 Material: Mild Steel, Painted semi-matt Black or 316/304 Stainless steel
 Length: 150mm or 300mm or 450mm.

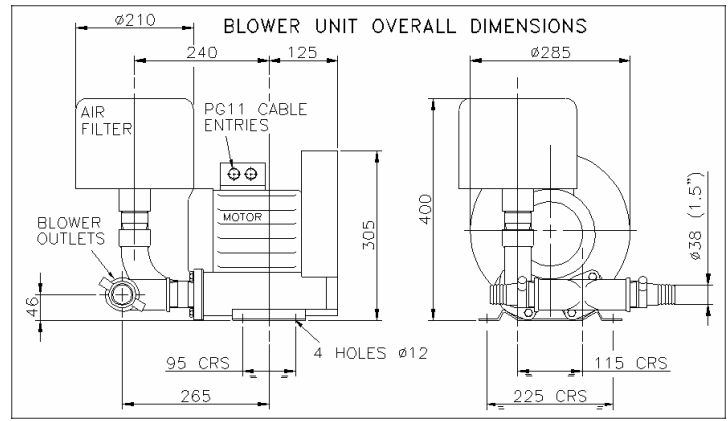

ORDERING INFORMATION AND MODEL CODE

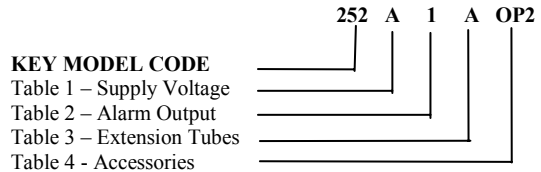

KEY MODEL CODE

- Table 1 – Supply Voltage
- Table 2 – Alarm Output
- Table 3 – Extension Tubes
- Table 4 - Accessories

KEY MODEL CODE

Code	Description
252	V.E. Monitor with Digital Display Control Unit Panel Mounting Transmitter and Receiver Units.

TABLE 1 - SUPPLY VOLTAGE

Code	Description
A	230V AC ± 10% 50/60Hz
B	115V AC ± 10% 50/60Hz

TABLE 2 – ALARM OUTPUT

Code	Description
1*	Volt Free Alarm Contact Normally Open
2	Volt Free Alarm Contact Normally Closed

TABLE 3 – EXTENSION TUBE

Code	Description
A	Stack Mounting Extension Tubes 150 mm Long
B	Stack Mounting Extension Tubes 300 mm Long
C	Stack Mounting Extension Tubes 450 mm Long

TABLE 4 – ACCESSORIES

Code	Description
OP2	Auxiliary 4-20mA Output Board VEM/168.
VEM/A116	Standard IP54 Blower Unit complete with Air Filter and supply fitting for connecting to Transmitter and Receiver Units. Supply Voltage to be advised by customer.
VEM/134	Flexible Hose from Blower to Transmitter/Receiver.
VEM/A111	Stack Adaptor Kit to convert old Model 210 to 252.
SO1/151	Alarm Bell.

	<p>SKIL ENVIRONMENTAL LIMITED GREENHEY PLACE SKELMERSDALE LANCASHIRE WN8 9SB UNITED KINGDOM</p>	<p>Telephone + 44 (0) 1695 714600 Fax: +44 (0) 1695 714611 e-mail: sales@skilenvironmental.com</p>
<p>©SKIL ENVIRONMENTAL LTD 03/01/06</p>		