

TECHNICAL BUREAU GRIEB

- LEVEL INDICATORS -

Mühlweg 22
D - 71 093 Weil im Schönbuch
Tel. 0 71 57 / 6 33 26
Fax. 07157 / 6 62 38

TECHNICAL INFORMATION

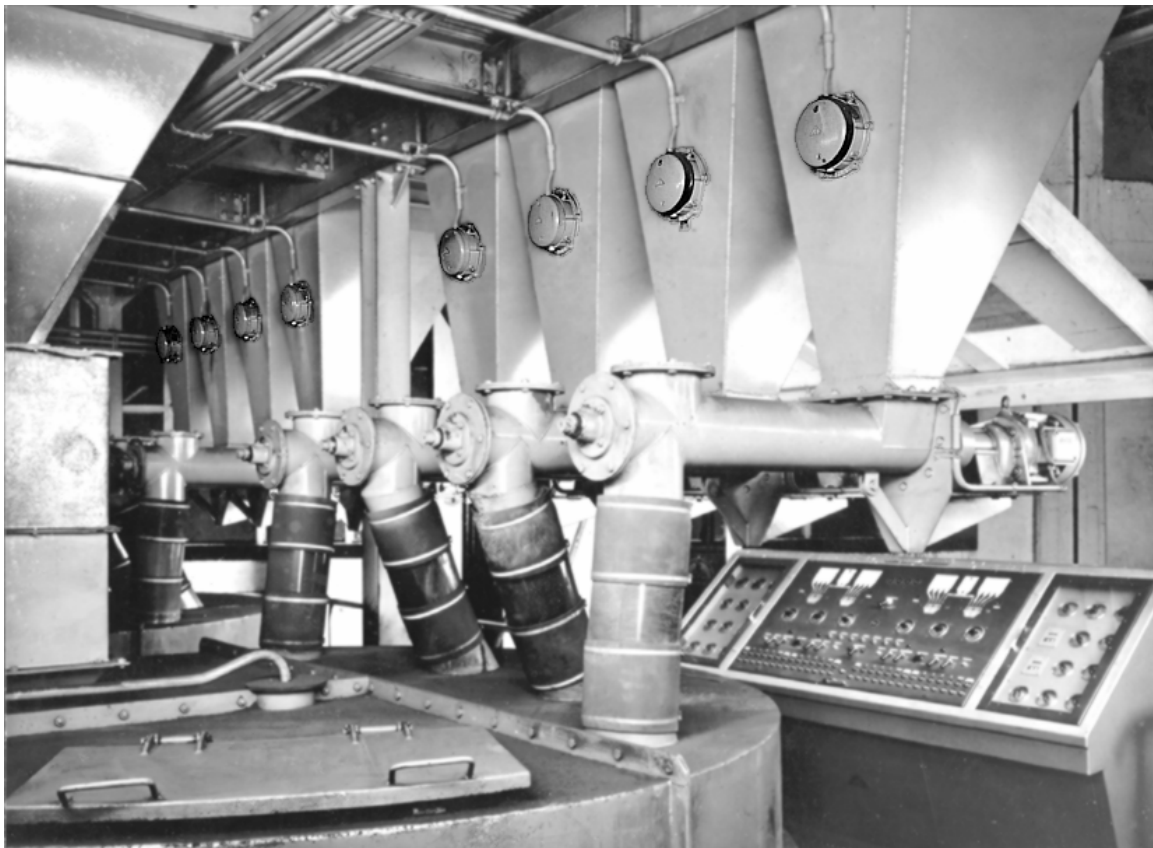

Level indicators in the silo discharges of an automatic preparation plant

Level Indicator **FM** Type **FMN** and **FMK**

Bank connection: *GENOSSENSCHAFTSBANK Weil im Schönbuch Germany*
(BLZ 600 692 24) *Account Nr. 63 171 007 Place of delivery: Weil i. Sch.*

Application

Level indicators with a membrane and micro contact are used to display the level of storage vessels / silos.

Range of application:

| Powdered, granular, crystalline material of different kinds

How it works

- The bulk material forces the membrane downwards.
- The membrane presses then on the two-way contact (normally open and closed contact) of the integrated micro switch.

The micro switch can be charged up to 15 amp (operational voltage 220V; 50 Hz)

The level indicators work with easily flowing bulk materials with big enough pour angle. Only such bulk materials generate an appropriate activation pressure on the membrane. The level indicators are usually installed at or in the silo wall. The necessary activation pressure depends on the design of the installed compression spring. The standard spring (20p) requires an operating pressure of approx. 20p to 50p. If stronger return springs are installed, the necessary activation pressure is accordingly higher. Two stronger return springs / exchange springs (60p; 250p) will be delivered free of charge with the level indicator.

Structure

A light metal case supports the membrane. The membrane is held by a ring of non-corroding material screwed onto the case. The membrane is pre-stressed by a spiral spring. The pre-stressing of the membrane can be increased if you exchange the spiral spring inserted with one of the stronger spiral springs.

This is important for:

- | **Bulk materials with particularly high specific weight,**
- | **Bulk material with a certain aggressiveness,**
- | **Conveyance with low pressure.**

If you convey with higher pressure within the silo, a simple pipe can adjust the lower air pressure which prevails behind the membrane in the level indicator.

The operating point of the micro switch can be changed as the micro switch is movable.

Advantage: The sensitivity of the level indicator can be adjusted to the:

- | **Character of the bulk material,**
- | **Installation conditions.**

Level indicator FMN 113 can also be used with wet bulk materials.

Auswahl

Different membranes should be used depending on the special characteristics of the bulk materials used. The weaker and less abrasion-resistant membranes are naturally somewhat more sensitive. They are particularly appropriate

- | For bulk materials with particularly low specific weight
- | Or in small containers.

The correct choice of the installation point is also very important.

The available membranes are:

Material	Used for
Perbunan 0,5 mm (PB 05) or Perbunan 1,0 mm (PB 10)	powdered materials with low specific weight: grime, chalk, PVC granulates, food (milk powder, flour, cocoa), semolina, rolled oats, rice, sugar, cacao beans, leguminous plants, salt, coffee, grain and bulk materials of similar structure
Viton 0,5 mm (VT 05) or Viton 1,0 mm (VT 10)	powdered bulk materials at higher temperatures. Moreover for: Cement, gypsum, fertilizer, dry sand, gravel and filling materials with stronger abrasion.

Membran characteristics:

Type of membrane	For indicator type	Device sensitivity	Abrasion resistance	Food	Temp. Range in °C	Fat constancy
PB 05	FMK 508	Very high	Average	Yes	-30 ... +100	Good
PB 10	FMN 113	Very high	Average	Yes	-30 ... +100	Good
VT 05	FMK 508	High	Very high	No	-30 ... +150	Very good
VT 10	FMN 113	High	Very high	No	-30 ... +150	Very good

Always choose the larger level indicator type

- | For bulk materials with greater grain size and stronger internal friction,
- | If the bulk materials tend to form crusts or bridges.

Attention!

These level indicators are conditionally suitable

- | For materials that strongly form crusts,
- | For materials with high internal friction (e.g. coke of larger granulation)

Type FMK 508

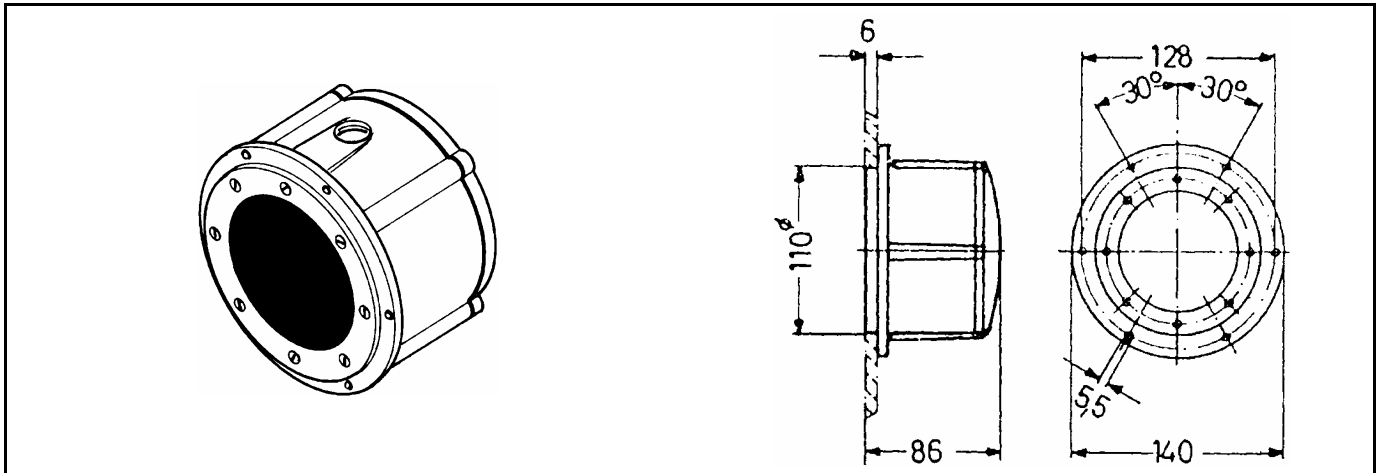

This small level indicator with a diaphragm diameter of only 110 mm has a fixed mounting flange. It has two tapped holes for screwing a PG11 for electrical connections.

Area of application:

- | Flat or slightly curved silo walls,
- | Wall thickness of max. 6mm,
- | Mounted from outside.

Shipped with:

- | A gasket
- | Two stronger reset springs

Type FMN 113

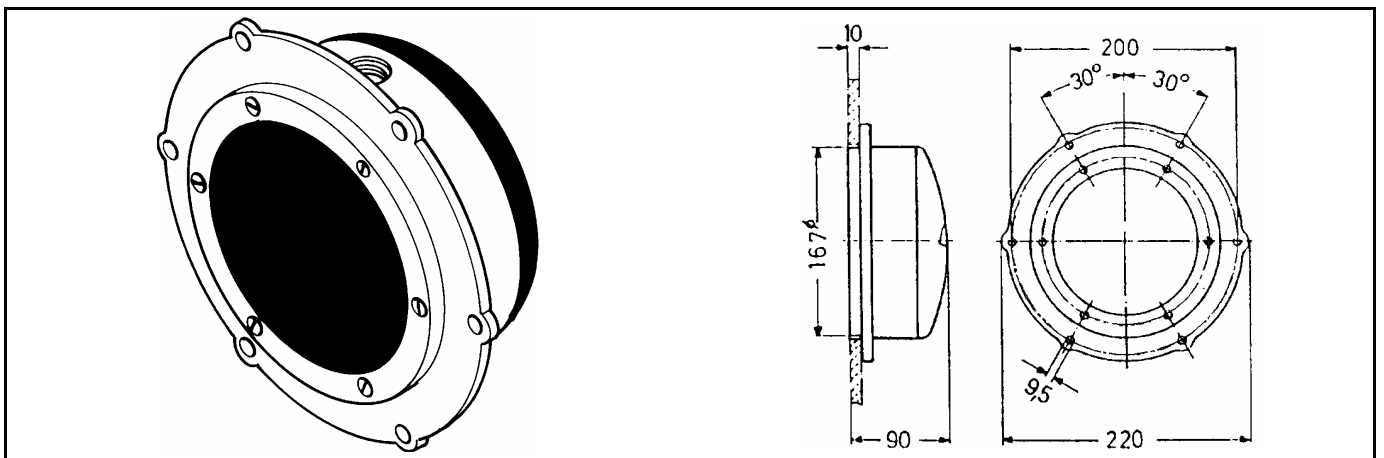

This standard version with a diaphragm diameter of only 167 mm has a fixed mounting flange. It has two tapped holes for screwing a PG11 for electrical connections.

Area of application:

- | Wall thickness of max. 10mm
- | Mounted from outside (reaching the inside of the silo)
- | Conductions mounted outside of the silo

Shipped with

- | A gasket
- | Two stronger reset springs

Tight fitting to the silo inner wall possible with several gaskets between flange and external wall.

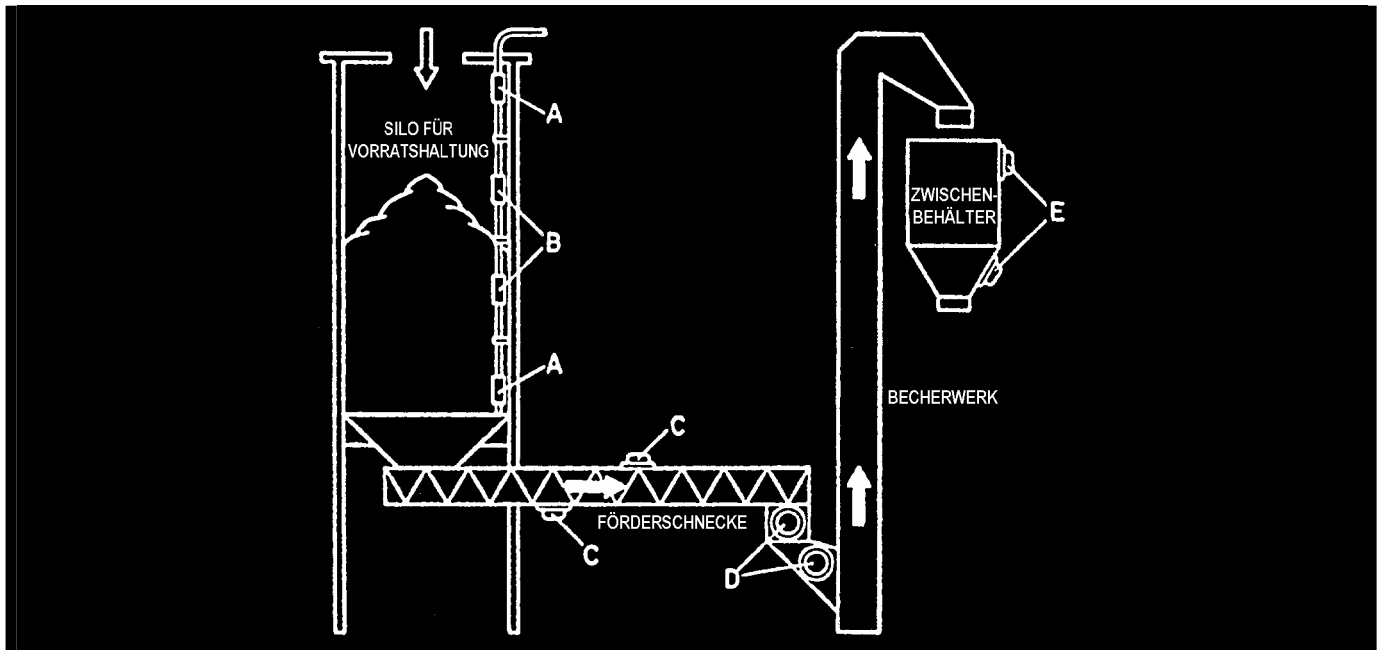

- A** Level indicator for interior assembly in a concrete supply silo showing full or empty levels by optical signal.
- B** Additional level indicators enable the display of any level between the full and empty signal.
- C** Installed on the upper and/or lower wall of an enclosed conveyor system, a level indicator can:
 - | indicate a blockage by an optical or acoustic signal.
 - | switch off the motor by a switching signal.
 - | warn of idle operation by optical or acoustic signal.
 - | control a smooth material-flow with appropriate electrical devices.
- D** Level indicators in the supply to the bucket conveyor indicate optically or acoustically:
 - | smooth material flow.
 - | blockage through excessive feeding causing electrical control equipment to switch of the automatic feeding.
- E** Level indicators for exterior mounting at an intermediate surge tank:
 - | To optically or acoustically announce the highest and/or deepest possible level.
 - | To automatically refill by appropriate electrical switching and control systems.

**All weights and measures are approximated.
Changes of specification, specifically weights and measures are reserved.**

Installation with very coarse-grained and sharp edged bulk material

With sharp edged filling material or filling material with large granulations we recommend the installation of rejecting devices.

The diagram shows an example:

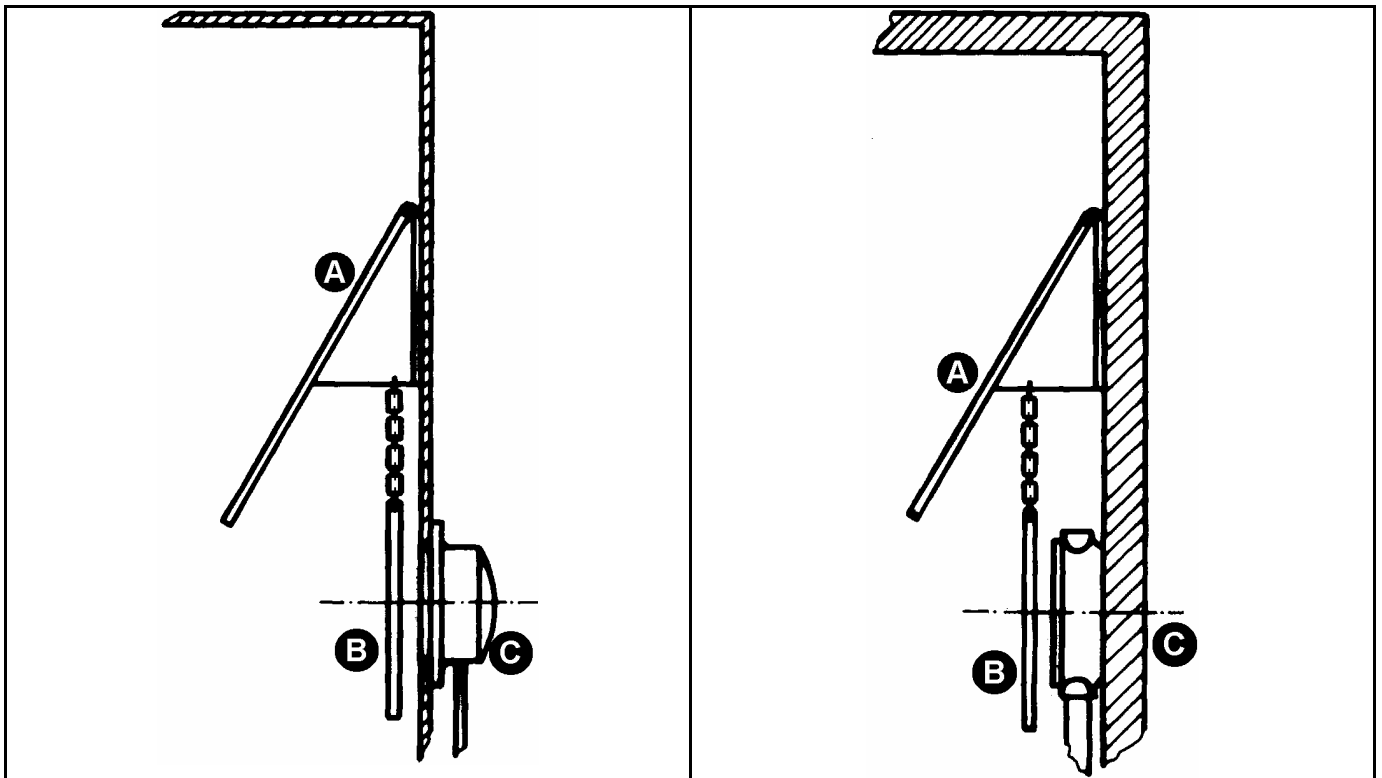

A = Rejection device **B** = Curtain made of rubber **C** = level indicator
or plastic

- The rejection device protects the level indicator and diaphragm from damages caused by falling filling material.
- The curtain protects the diaphragm against high abrasion, because it lies over the diaphragm, if the filling level increases.



The indicator may not lie in the flow of the filling material, otherwise the indicator and diaphragm will be damaged rapidly!