

BASE

Rotary limit switch



Rotary limit switch used to control and measure the movement of industrial machines. Its compact size make it suitable for use in narrow spaces.

FEATURES

- It consists of a gear motor that transfers movement through a primary input reduction stage (worm gear and helical toothed gear) and one or more secondary output stages (pairs of straight toothed gears).
- Accurate adjustment of cams by means of screws.
- Positive opening NC contacts for safety functions.
- Mechanical life of switches: 1 million operations.
- IP protection degree: Base is classified IP42, IP65 or IP66, IP67 and IP69K.
- NEMA protection degree: Base IP66, IP67 and IP69K is classified Type 3; Base IP42 is classified Type 1.
- Extreme temperature resistance: -40°C to +80°C.
- It features stainless steel transmission and gear driving shafts, self-lubricating technopolymer gears and driving bushes, technopolymer base and cover.
- Sintered bronze bushes are moulded into the base of the limit switch to optimize shaft rotation and prevent rubbing with plastic material.
- All materials and components used are wear resistant and guarantee protection of the unit against water and dust.

OPTIONS

- Revolution ratios from 1:15 to 1:1500, achieved by combining different secondary output stages.
- Snap action switches with 1NO+1NC change-over contacts.
- It can be equipped with a cam set with maximum 6 switches.
- Dedicated cable clamps or connectors.
- Available with anti-moisture plug fitted to the base by means of a lock nut, to improve transpiration for the limit switch whilst maintaining protection against water.
- Available with flanges, pinions and couplings.
- Available with direct control switches to enable direct action on the motor.

CERTIFICATIONS

- CE marking, cURus* marking and EAC certification.
- Complies with accident prevention regulation BGV C 1 (only for Germany).

Use the online configurator (<https://configuratore.terworld.com>) or fill in the request form for accurate product configuration.

* Not available on all versions.

POSSIBLE ASSEMBLIES

IP 42 with 2 switches

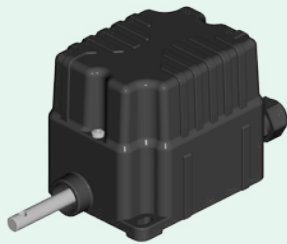

IP 66/IP 67/IP 69K, with 2 switches and flange

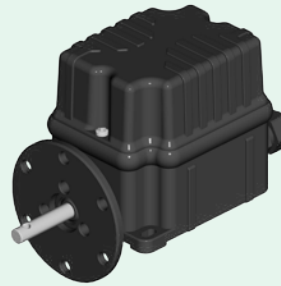

IP 66/IP 67/IP 69K, with 3 or 4 switches



With anti-moisture plug

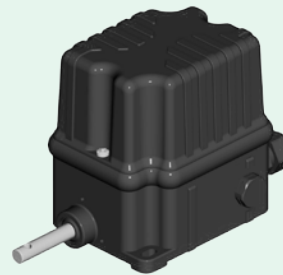



CERTIFICATIONS

Conformity to Community Directives	2014/35/UE Low Voltage Directive
	2006/42/CE Machinery Directive
	EN 60204-1 Safety of machinery - Electrical equipment of machines
	EN 60204-32 Safety of machinery - Electrical equipment of machines - Requirements for hoisting machines
Conformity to CE Standards	EN 60947-1 Low-voltage switchgear and controlgear
	EN 60947-5-1 Low-voltage switchgear and controlgear - Control circuit devices and switching elements - Electromechanical control circuit devices
	EN 60529 Degrees of protection provided by enclosures
Conformity to cULus Standards	CSA-C22.2 No 14-13 Industrial Control Equipment
	UL 508 Industrial Control Equipment
BGV C 1	Regulations for the prevention of accidents BGV C 1 (only for Germany)
Markings and homologations	Version IP42 or IP65:  
	Version IP 66/IP 67/IP 69K:   



GENERAL TECHNICAL SPECIFICATIONS

Ambient temperature	Storage -40°C/+80°C
	Operational -40°C/+80°C
IP protection degree	IP 42
	IP 65
	IP 66/IP 67/IP 69K
NEMA protection degree	Type 3 (version IP 66/IP 67/IP 69K)
Insulation category	Class II
Maximum rotation speed	800 rpm
Cable entry	Cable clamp M16

TECHNICAL SPECIFICATIONS OF THE MICROSWITCHES FOR AUXILIARY CONTROL

Code	PRSL0003XX	PRSL0011XX
Utilisation category	AC 15	
Rated operational voltage	250 Vac	
Rated operational current	3 A	
Rated thermal current	10 A	
Rated insulation voltage	300 Vac	
Mechanical life	1x10 ⁶ operations	
Connections	6.3 mm Faston tap	Screw-type terminal
Wires	-	2x0.5mm ² , 2x1.5 mm ² , 1x2.5 mm ²
Tightening torque	-	0.5 Nm
Microswitch type	Single break, snap action	
Contacts	1NO+1NC change-over contacts (All NC contacts are of the positive opening operation type )	
Scheme		
Markings and homologations		

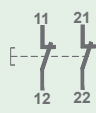
TECHNICAL SPECIFICATIONS OF THE MICROSWITCHES FOR DIRECT CONTROL

Code	PRSL0455PI
Utilisation category	AC 3
Rated operational current	400 Vac
Rated operational voltage	10 A
Rated thermal current	20 A
Rated insulation voltage	660 Vac
Mechanical life	1x10 ⁶ operations
Connections	Screw-type terminal
Wires	2x1.5 mm ² , 1x2.5 mm ²
Tightening torque	0.8 Nm
Microswitch type	Two-pole
Contacts	2NC (All NC contacts are of the positive opening operation type )
Scheme	
Markings and homologations	

OVERALL DIMENSIONS (mm)

Limit switches with sets of 5 or 6 PRSL0003XX/PRSL0011XX switches and with sets of 2 PRSL0455PI switches have a special cover: overall dimensions and code numbers are available on request.

IP 42 or IP 65

- * 2 PRSL0003XX / PRSL0011XX switches or 1 PRSL0455PI switch
- () 3/4 PRSL0003XX / PRSL0011XX switches

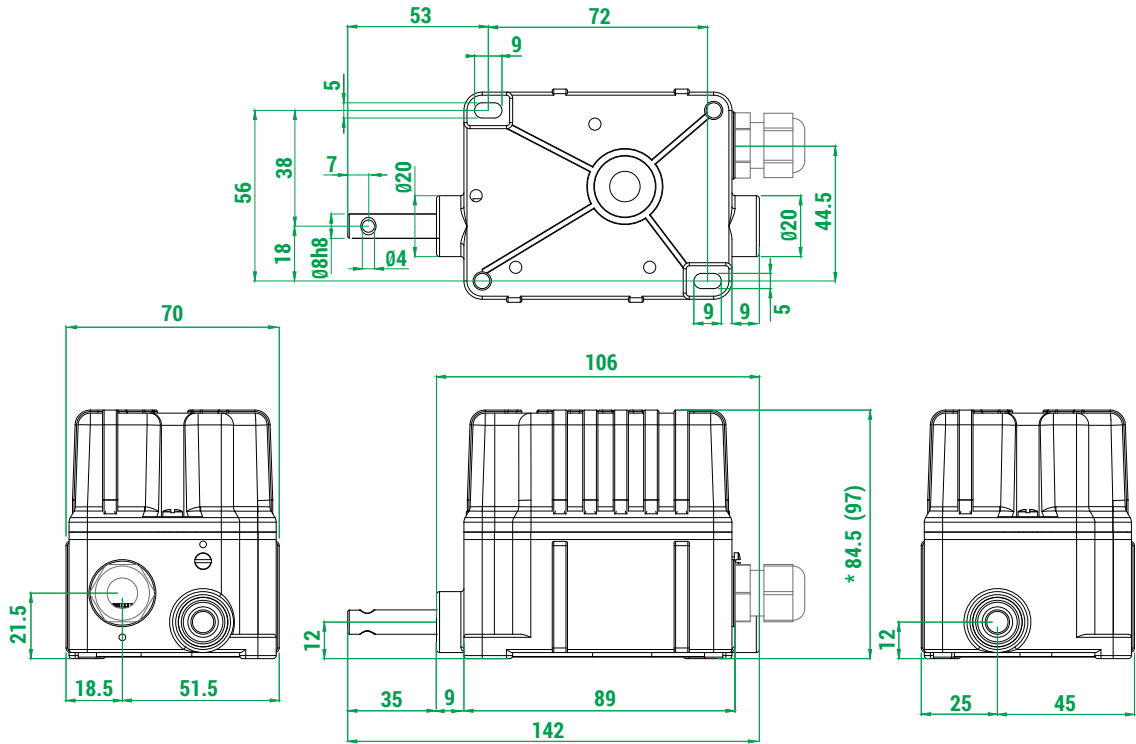

IP 66 / IP 67 / IP 69K

- * 2/3 PRSL0003XX / PRSL0011XX switches or 1 PRSL0455PI switch
- () 4 PRSL0003XX / PRSL0011XX switches

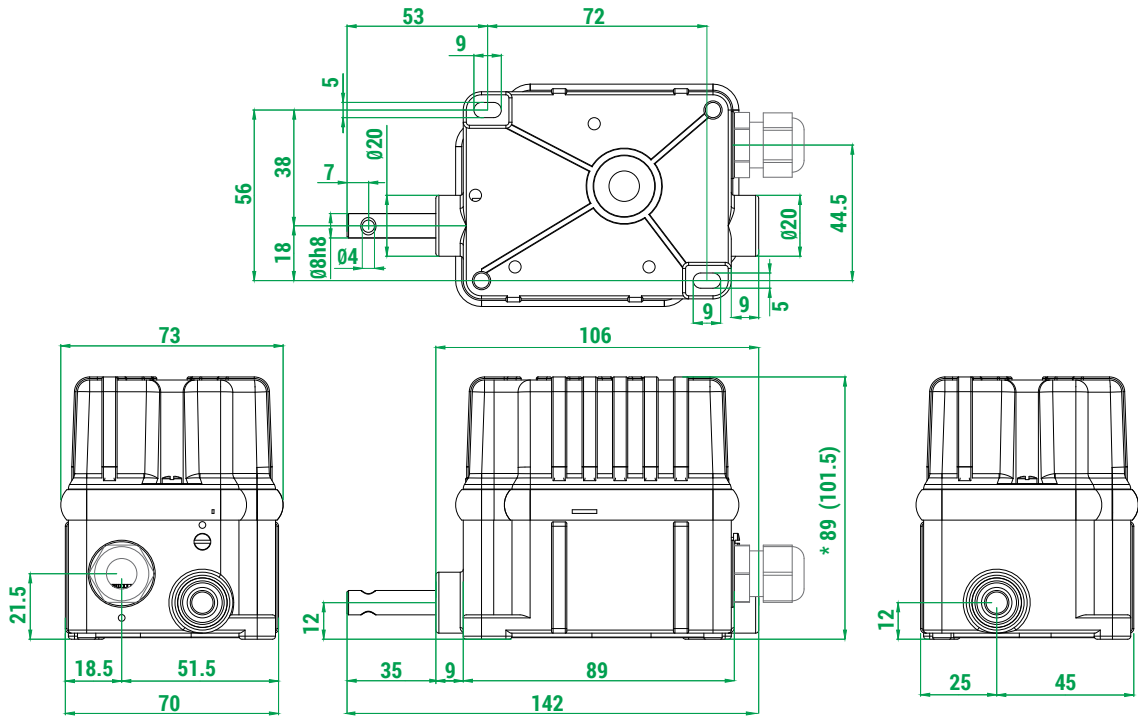

IP 42 or IP 65 with flange

- * 2 PRSL0003XX / PRSL0011XX switches or 1 PRSL0455PI switch
- () 3/4 PRSL0003XX / PRSL0011XX switches

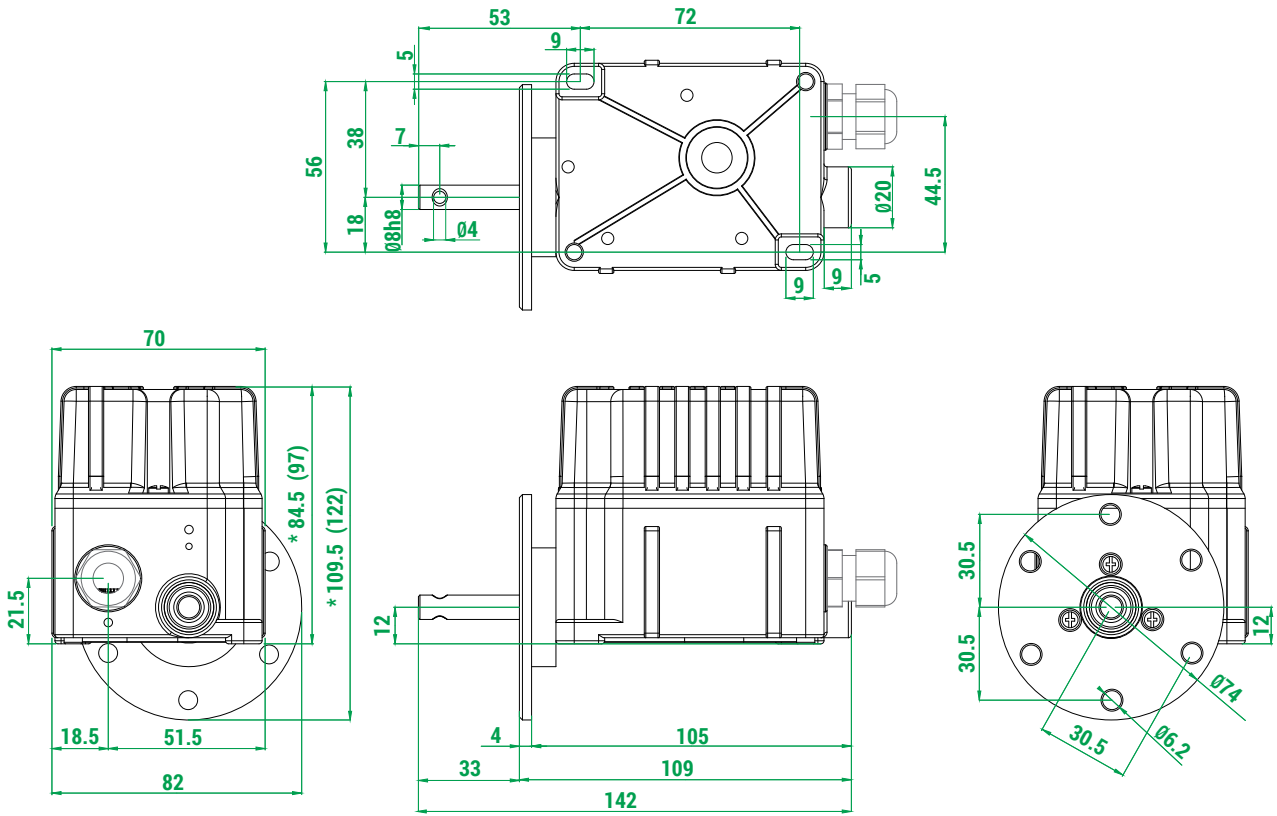

IP 66 / IP 67 / IP 69K with flange

- * 2-3 PRSL0003XX / PRSL0011XX switches or 1 PRSL0455PI switch
- () 4 PRSL0003XX / PRSL0011XX switches

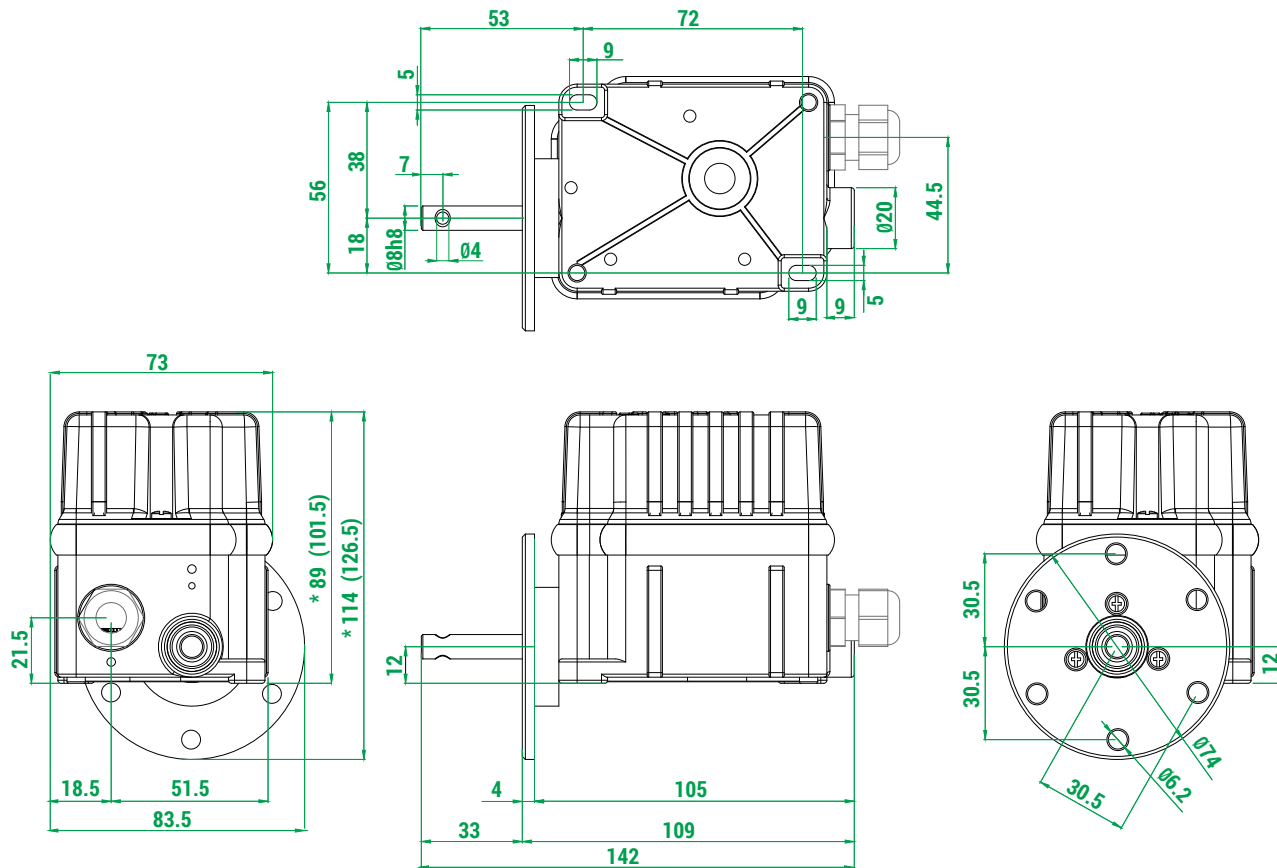

EXPLODED DRAWING

4

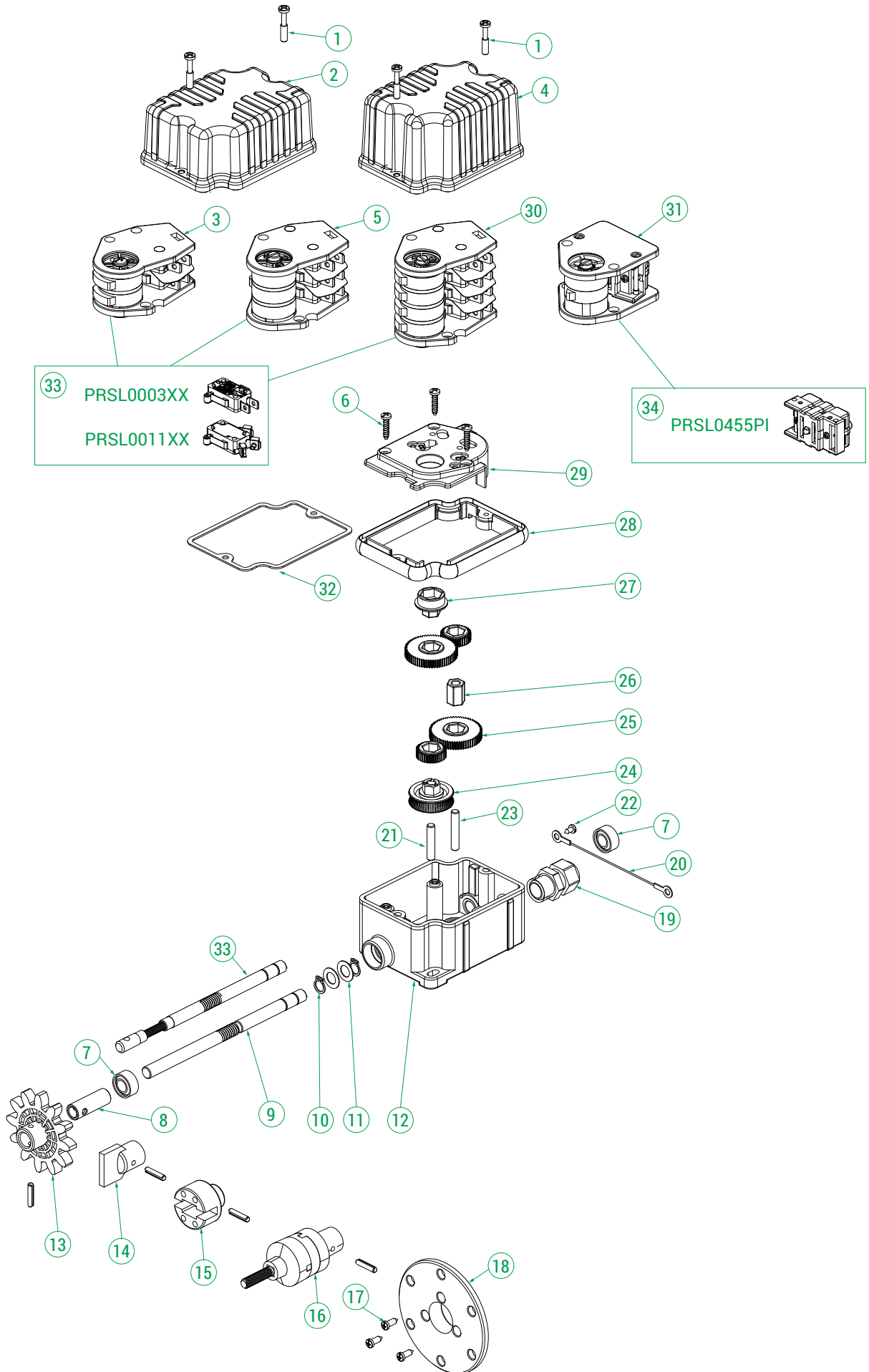

STANDARD LIMIT SWITCHES

Standard limit switches are equipped with 1NO+1NC change-over switches for auxiliary control PRSL0003XX cams PRSL7140PI .

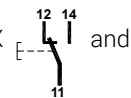

Rated revolution ratio	Real revolution ratio	No. of cams and switches	IP 42	IP 65	IP 66 / IP 67 / IP 69K
			CE EAC	CE EAC	CE cRU US EAC
			Code	Code	Code
1:15	1:15.82	2	PFA9142A0015001	PFA9165A0015003	PFA9067A0015001
		3	PFA9142A0015003	PFA9165A0015004	PFA9067A0015003
		4	PFA9142A0015002	PFA9165A0015005	PFA9067A0015002
1:20	1:20.37	2	PFA9142A0020001	PFA9165A0020001	PFA9067A0020001
		3	PFA9142A0020003	PFA9165A0020003	PFA9067A0020003
		4	PFA9142A0020002	PFA9165A0020002	PFA9067A0020002
1:25	1:25.96	2	PFA9142A0025001	PFA9165A0025004	PFA9067A0025001
		3	PFA9142A0025003	PFA9165A0025005	PFA9067A0025003
		4	PFA9142A0025002	PFA9165A0025006	PFA9067A0025002
1:50	1:50	2	PFA9142A0050001	PFA9165A0050002	PFA9067A0050001
		3	PFA9142A0050003	PFA9165A0050003	PFA9067A0050003
		4	PFA9142A0050002	PFA9165A0050004	PFA9067A0050002
1:75	1:75	2	PFA9142A0075001	PFA9165A0075001	PFA9067A0075001
		3	PFA9142A0075001	PFA9165A0075003	PFA9067A0075003
		4	PFA9142A0075002	PFA9165A0075002	PFA9067A0075002
1:100	1:103.57	2	PFA9142A0103001	PFA9165A0103001	PFA9067A0103001
		3	PFA9142A0103003	PFA9165A0103003	PFA9067A0103003
		4	PFA9142A0103002	PFA9165A0103002	PFA9067A0103002
1:150	1:158.02	2	PFA9142A0158001	PFA9165A0158001	PFA9067A0158001
		3	PFA9142A0158003	PFA9165A0158003	PFA9067A0158003
		4	PFA9142A0158002	PFA9165A0158002	PFA9067A0158002

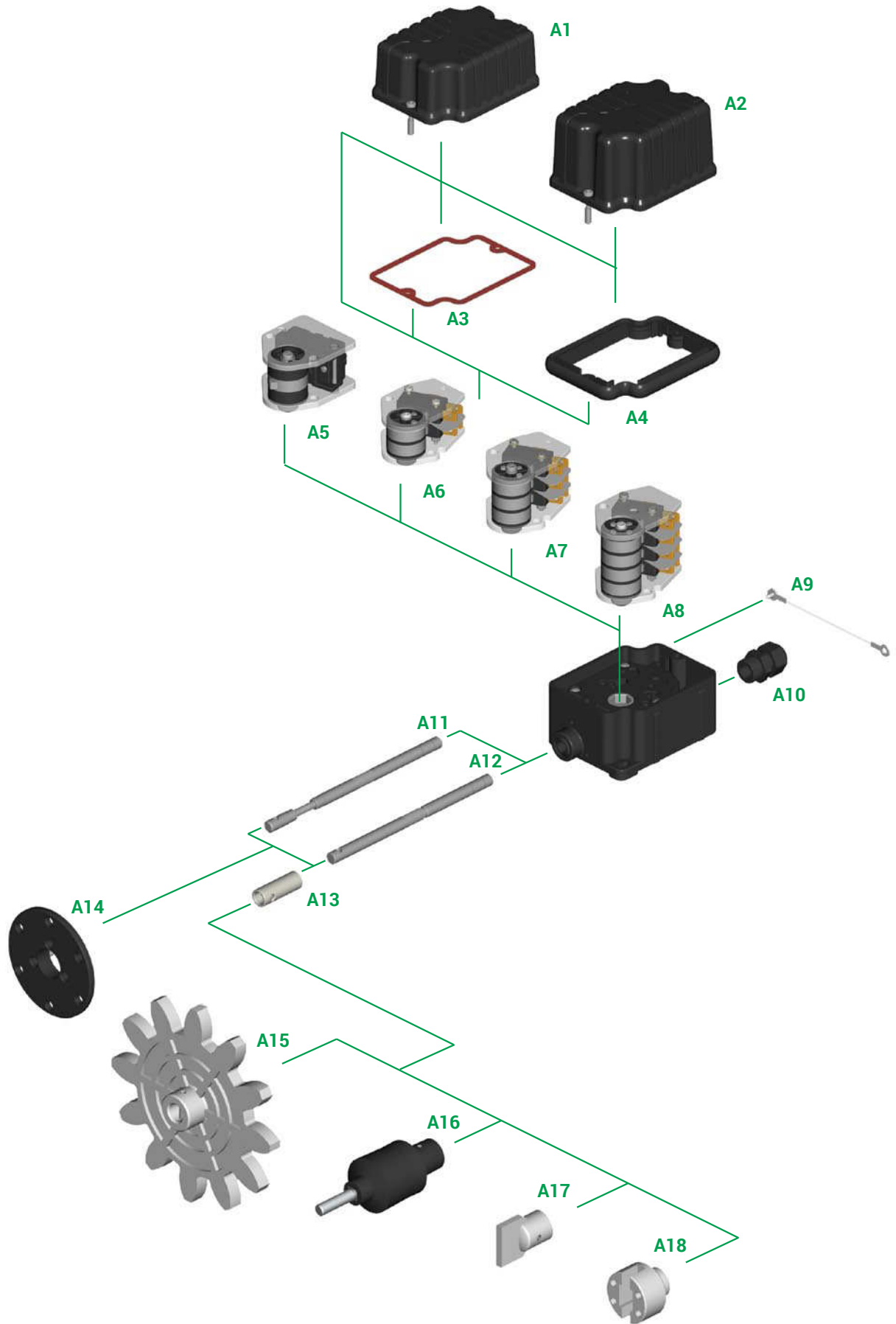

ASSEMBLY DRAWING

4





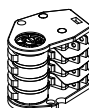

COMPONENTS

Standard cam sets







Ref.	Drawing	No. and type of cams	No. and type of switches	Code
A5		1 cam A	1 PRSL0455PI switch	PRFC0101PE
A6		2 cams A	2 PRSL0003XX switches	PRFC0008PEC
		2 cams C	2 PRSL0003XX switches	PRFC0009PEC
A7		3 cams A	3 PRSL0003XX switches	PRFC0004PEC
		3 cams C	3 PRSL0003XX switches	PRFC0006PEC
A8		4 cams A	4 PRSL0003XX switches	PRFC0202PEC
		4 cams C	4 PRSL0003XX switches	PRFC0198PEC

Other sets with 2/3/4/5 or 6 switches PRSL0003XX/PRSL0011XX or with 1 or 2 switches PRSL0455PI are available on request.







Cam reference chart

Cam	Switching angle	Code
A 	1 point 20.5° ±0.5°	PRSL7140PI
B 	10 points 14.0° ±0.5°	PRSL7142PI
C 	60° sector 78.0° ±0.5°	PRSL7141PI
E 	180° sector 199.5° ±0.5°	PRSL7144PI
H 	335° sector 344.0° ±0.5°	PRSL7143PI

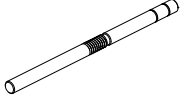
Accessories

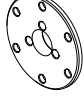
Ref.	Drawing	Description	Code
A1		Cover with screws for Base IP 42 or IP 65 with 2 switches	PA090013
		Cover with screws per Base IP 66/IP 67/ IP 69K with 2/3 switches	PA090010
A2		Cover with screws for Base IP 42 or IP 65 or IP 66/IP 67/IP 69K with 3/4 switches	PA090011
A3		Gasket for Base IP 65	PRGU1085PE
A4		Tightening rubber for Base IP 66/IP 67/IP 69K	PRGU1200PE
A9		Cover holding wire + screw (bag with 10 pieces)	PRSL0358PI
A10		Cable clamp M16	PRPS0062PE

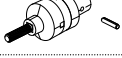
Accessories

Ref.	Drawing	Description	Code
A11		Flexible shaft	ALL1F00001
A12		Standard shaft	ALL1R00001
A13		Bush \varnothing 8 to \varnothing 12 for pinion gear/coupling	PRT01075PE
A14		Flange	PRT04040PE
A15		Pinion gear	See pinion gear tables
A16		Coupling with pin	PRSL0981PI
A17		Male coupling with pin	PRSL0919PI
A18		Female coupling with pin	PRSL0920PI

Moulded pinion gears

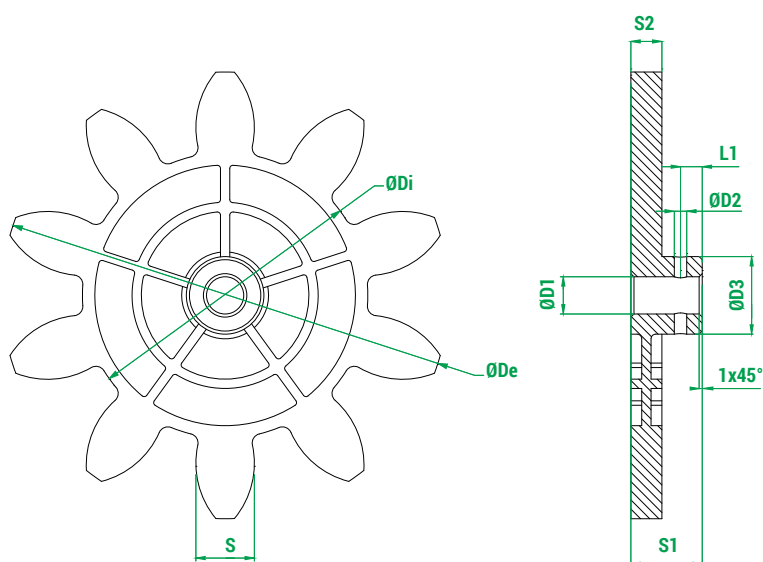

Legend

Z	Number of teeth
M	Module
Dp	Primitive diameter
De	External diameter
Di	Internal diameter
a	Addendum
d	Dedendum
Alpha	Pressure angle

Code	Z	M	Dp	De	Di	a	d	S	Alpha	D1	D2	D3	S1	S2	L1
PRSL0971PI	8	2.50	20.00	25.00	14.15	2.50	2.93	3.93	20.00	8.00	2.50	14.00	18.00	8.00	4.00
PRSL0915PI	8	20.00	160.00	200.00	113.20	20.00	23.40	31.41	20.00	12.00	4.00	24.00	23.00	10.00	7.00
PRSL0964PI	9	2.50	22.50	27.50	16.25	2.50	3.13	3.93	20.00	8.00	2.50	13.50	18.00	8.00	4.00
PRSL0963PI	9	3.50	31.50	38.50	23.40	3.50	4.10	4.71	20.00	8.00	2.50	14.00	18.00	8.00	4.00
PRSL0892PI	9	5.00	45.00	56.00	36.00	5.50	4.50	9.19	20.00	8.00	2.50	16.00	18.00	8.00	4.00
PRSL0968PI	10	3.00	30.00	36.00	23.00	3.00	3.51	4.71	20.00	8.00	2.50	14.00	18.00	8.00	4.00
PRSL0912PI	10	12.00	120.00	144.00	92.00	12.00	14.00	18.85	20.00	12.00	4.00	25.00	23.00	10.00	7.00
PRSL0913PI	10	14.00	140.00	168.00	107.24	14.00	16.38	21.99	20.00	12.00	4.00	24.60	23.00	10.00	7.00
PRSL0914PI	10	16.00	160.00	192.00	122.67	16.00	18.67	25.13	20.00	12.00	4.00	24.00	23.00	10.00	7.00
PRSL0917PI	11	6.00	66.00	78.00	51.96	6.00	7.02	9.42	20.00	12.00	4.00	19.00	23.00	8.00	7.00
PRSL0916PI	12	5.00	60.00	70.00	48.30	5.00	5.83	7.85	20.00	12.00	4.00	20.00	23.00	8.00	7.00
PRSL0918PI	12	8.00	96.00	112.00	77.28	8.00	9.36	12.56	20.00	12.00	3.90	21.50	23.50	10.00	7.00
PRSL0911PI	12	10.00	120.00	140.00	96.67	10.00	11.67	15.71	20.00	12.00	4.00	25.00	23.50	10.00	7.00
PRSL0944PI	12	12.00	144.00	168.00	116.00	12.00	14.00	18.85	20.00	12.00	4.00	24.00	23.00	10.00	7.00

Measuring unit: mm.

Waterjet cut pinion gears

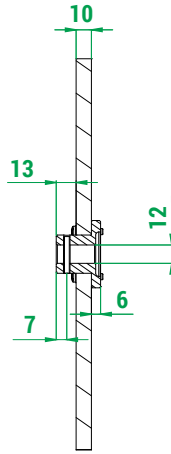
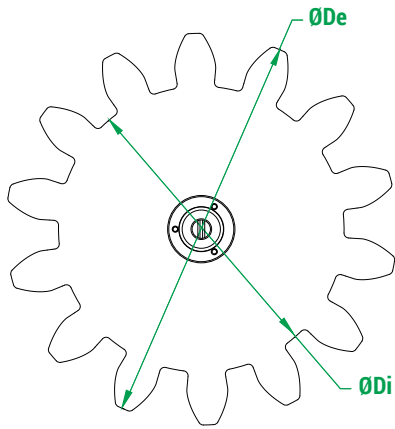

Legend

Z	Number of teeth
M	Module
Dp	Primitive diameter
De	External diameter
Di	Internal diameter
a	Addendum
d	Dedendum
Alpha	Pressure angle

Code	Z	M	Dp	De	Di	a	d	Alpha
PRSL0857PI	8	18.00	144.00	180.00	102.00	18.00	21.00	20.00
PRSL0855PI	8	24.00	192.00	240.00	136.00	24.00	28.00	20.00
PRSL0992PI	9	10.00	90.00	110.00	66.67	10.00	11.67	20.00
PRSL0879PI	9	16.00	144.00	176.00	106.67	16.00	18.67	20.00
PRSL0854PI	9	18.00	162.00	198.00	120.00	18.00	21.00	20.00
PRSL0871PI	9	20.00	180.00	220.00	133.33	20.00	23.33	20.00
PRSL0849PI	9	24.00	216.00	264.00	160.00	24.00	28.00	20.00
PRSL0846PI	10	10.00	100.00	120.00	76.67	10.00	11.67	20.00
PRSL0993PI	10	18.00	180.00	216.00	138.00	18.00	21.00	20.00
PRSL0970PI	10	22.00	220.00	264.00	168.52	22.00	25.74	20.00
PRSL0856PI	10	24.00	240.00	288.00	180.00	24.00	28.00	20.00
PRSL0861PI	11	12.00	132.00	156.00	104.00	12.00	14.00	20.00
PRSL0998PI	11	18.00	198.00	234.00	156.00	18.00	21.00	20.00
PRSL0997PI	11	20.00	220.00	260.00	173.36	20.00	23.32	20.00
PRSL0859PI	11	24.00	264.00	312.00	204.00	24.00	30.00	20.00
PRSL0863PI	12	14.00	168.00	196.00	133.00	14.00	17.50	20.00
PRSL0897PI	12	16.00	192.00	224.00	154.67	16.00	18.67	20.00
PRSL0972PI	12	18.00	216.00	252.00	173.88	18.00	21.06	20.00
PRSL0845PI	12	20.00	240.00	280.00	193.34	20.00	23.32	20.00
PRSL0878PI	12	24.00	288.00	336.00	232.00	24.00	28.00	20.00
PRSL0860PI	13	6.00	78.00	90.00	63.00	6.00	7.50	20.00
PRSL0853PI	13	12.00	156.00	178.59	126.00	11.29	15.00	20.00
PRSL0898PI	13	16.00	208.00	240.00	170.67	16.00	18.66	20.00
PRSL6519PI	14	6.00	84.00	96.00	69.00	6.00	7.50	20.00
PRSL0862PI	14	10.00	140.00	169.00	125.00	15.00	7.50	20.00
PRSL0896PI	14	16.00	224.00	256.00	186.67	16.00	18.67	20.00
PRSL0999PI	14	18.00	252.00	288.00	210.00	18.00	21.00	20.00
PRSL0848PI	14	20.00	280.00	320.00	233.33	20.00	23.33	20.00
PRSL0858PI	15	18.00	270.00	306.00	228.00	18.00	21.00	20.00
PRSL0847PI	16	20.00	320.00	360.00	273.33	20.00	23.33	20.00
PRSL0973PI	17	10.00	170.00	190.00	145.00	10.00	12.50	22.89
PRSL0974PI	17	14.00	238.00	266.00	203.00	14.00	17.50	22.89
PRSL0851PI	20	6.00	120.00	132.00	105.00	6.00	7.50	22.89
PRSL0844PI	25	1.00	25.00	27.00	22.50	1.00	1.25	22.89

Measuring unit: mm.



BASE - REQUEST FORM FOR NON STANDARD LIMIT SWITCH

Instructions

- 1 Version:** tick the required version.
- 2 Standard cam set:** write the code of the cam set required.
- 3 Customized cam set:** for non standard cam sets, fill in the scheme choosing the cams and the switches required. In case switch PRSL0455PI is required, it is possible to use only one switch.
Customized cams are available on request.
Sets with 5/6 switches PRSL0003XX/PRSL0011XX and with 2 switches PRSL0455PI are available on request.
- 4 Version with anti-moisture plug:** tick when the anti-moisture plug is required.
- 5 Cover holding wire:** tick when the cover holding wire is required.
- 6 Revolution ratio:** write the required revolution ratio.
- 7 Shaft:** tick the shaft type required.
Customized shafts are available on request.
- 8 Coupling, flange, pinion gear:** tick the box when coupling, flange or pinion gear are required.
When a standard pinion gear is required, write the code number listed in the pinion gear charts in the catalogue.
When a special pinion gear is required, write the number of teeth, the module and the primitive diameter.

Version 1

- IP00 (without cover) **CE EAC**
- IP42 **CE EAC**
- IP65 **CE EAC**
- IP66 / IP67 / IP69K **CE EAC cURus**

ATTENTION: Limit switches with anti-moisture plug are not cURus certified.
Special limit switches with 5-6 switches PRSL0003XX/PRSL0011XX are not EAC nor cURus certified.
All limit switches with switches PRSL0455PI are not EAC nor cURus certified.

Standard cam set 2

Cam set code _____

Customized cam set 3

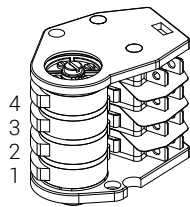

Cam code	Switch code
4 _____	_____
3 _____	_____
2 _____	_____
1 _____	_____

Version with anti-moisture plug 4

Cover holding wire 5

Revolution ratio 6

- | | |
|-------------------------------|--|
| <input type="checkbox"/> 1:15 | <input type="checkbox"/> 1:75 |
| <input type="checkbox"/> 1:20 | <input type="checkbox"/> 1:100 |
| <input type="checkbox"/> 1:25 | <input type="checkbox"/> 1:150 |
| <input type="checkbox"/> 1:50 | <input type="checkbox"/> 1: <input type="text"/> |

7 **Standard shaft** **Flexible shaft**

- Male coupling** **Coupling** **8**
- Female coupling** **Flange**
- Pinion gear**

Pinion gear code _____

Customized pinion gear

No. of teeth _____

Module _____

Primitive diameter _____

2 Legend - Standard cam sets

No. & type of switches	No. & type of cams	Code
1 x PRSL0455PI	1 cam A	PRFC0101PE
2 x PRSL0003XX	2 cams A	PRFC0008PEC
	2 cams C	PRFC0009PEC
3 x PRSL0003XX	3 cams A	PRFC0004PEC
	3 cams C	PRFC0006PEC
4 x PRSL0003XX	4 cams A	PRFC0202PEC
	4 cams C	PRFC0198PEC

3 Legend - Standard cams

Cam	Switching angle	Code
A	1 point 20,5° ±0,5°	PRSL7140PI
B	10 points 14,0° ±0,5°	PRSL7142PI
C	60° sector 78,0° ±0,5°	PRSL7141PI
E	180° sector 199,5° ±0,5°	PRSL7144PI
H	335° sector 344,0° ±0,5°	PRSL7143PI

Legend - Switches

Auxiliary control	Direct control
PRSL0003XX	PRSL0011XX
1NO+1NC	1NO+1NC
	PRSL0455PI
	2NC

USE AND MAINTENANCE INSTRUCTIONS

Base rotary limit switch is an electromechanical device for low voltage control circuits (EN 60947-1, EN 60947-5-1) to be used as electrical equipment on machines (EN 60204-1) in compliance with the fundamental requirements of the Low Voltage Directive 2014/35/UE and of the Machine Directive 2006/42/CE.

The limit switch is designed for use in industrial environments under even severe climatic conditions (operational temperature from -40°C to $+80^{\circ}\text{C}$, suitable for use in tropical environment). The equipment is not suitable for use in environments with potentially explosive atmosphere, corrosive agents or a high percentage of sodium chloride (saline fog). Oils, acids or solvents may damage the equipment; avoid using them for cleaning. Do not connect more than one phase to each switch. Do not oil or grease the control elements or the switches.

The installation of the limit switch shall be carried out by expert and trained personnel. Wiring shall be properly done according to the current instructions.

Prior to the installation and the maintenance of the limit switch, the main power of the machinery shall be turned off.

Steps for the proper installation of the limit switch

- Loosen the fixing screw (4) and remove the cover (3.)
- Connect the limit switch shaft (2) to the reduction gear shaft avoiding any misalignment between the two shafts.
- Fix the limit switch firmly in place to prevent abnormal vibrations of the equipment during operation; use only the fixing holes on the base (1) to fix the equipment.
- Tighten the cable clamp (5) into appropriate place.
- Insert the cable into the limit switch through the cable clamp (5).
- Strip the cable to a length suitable for wiring the switches.
- Tape the stripped part of the cable.
- Clamp the wire into the cable clamp (5).

- Connect the switches according to the contact scheme printed on the switches or to the wiring scheme on the back of the instructions (use 6.3 mm Faston taps).
- Adjust the operating point of the cams; for proper adjustment, loosen the central screw (7) of the cam set, adjust the operating point of each single cam by turning its screw (8) (the numbers on the screws refer to the cams counting from bottom to top), then tighten the central screw (7).
- Insert the free end of the no-drop wire (9), if used, into one of the screws (4), then close the limit switch using the screws (4); check the proper positioning of the rubber (6) in the cover (03) and tighten the screws (4) with a torque of 80/100 cNm.

Periodic maintenance steps

- Check the proper tightening of the screws (4) and cover (3).
- Check the proper tightening of the central screw (7) holding the cams.
- Check the wiring conditions (in particular where wires clamp into the switch).
- Check the conditions of the rubber (6) fit between the cover (3) and the base (1) and check the tightening of the cable clamp (5) around the cable.
- Check that the limit switch enclosure (1, 3) is not broken.
- Check the alignment between the limit switch shaft (2) and the reduction gear shaft.
- Check that the limit switch is properly fixed.
- If there is an anti-moisture plug, check its conditions.

In case any component of the limit switch is modified, the validity of the markings and the guarantee on the equipment are annulled. Should any component need replacement, use original spare parts only.

TER declines all responsibility for damages caused by the improper use or installation of the equipment.

IP 42

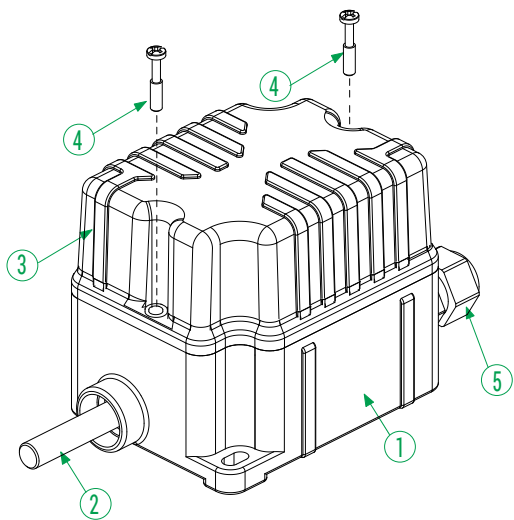

IP 65

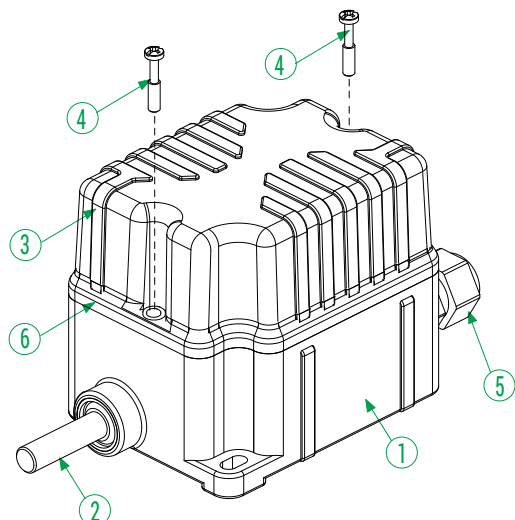

IP 66/IP 67/IP 69K

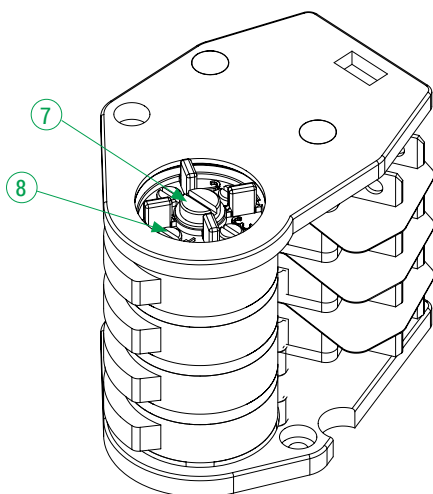
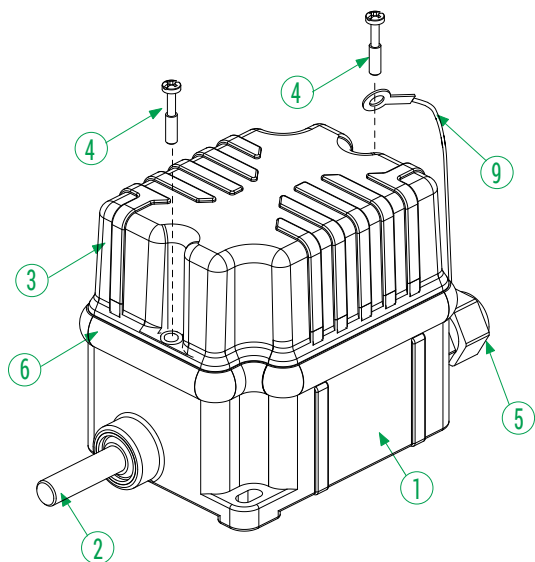

Image for illustrative purpose only.
 Number and type of cams differ depending on the model.

