

GP10-2 POWERPACK



TECHNICAL SPECIFICATION

GP10-2 POWERPACK

Part No KA/5001 (hand start)
KA/5001E (electric start)

Application

The GP10-2 and the GP10-2E power pack is designed for use in emergency oil spill response activities, they are powered by a single cylinder, air cooled diesel engine and are used to provide hydraulic power to Vikoma oil recovery equipment via two independent supply lines.

Dimensions

Length 110cm
Width 71cm
Height 76cm
Weight 121Kg without fuel/oil - Manual start
139Kg without fuel/oil - Electric start

Construction

Base frame Stainless steel
Hydraulic tank Mild steel
Upper frame Stainless steel tube
Paint finish Mild steel work shot blasted, 2 coats epoxy primer and 2 coats polyurethane enamel - RAL 2008
Wheels Tyre on steel rim with nylon axle bearings
Lifting 4 point lift

Performance

150 bar maximum system pressure.
3/4" QRC 16 l/min @ 135 bar – pump 2
39 l/min @ 80 bar – pump 1
58 l/min @ 56 bar – pump 1&2
1/2" QRC 0-30 l/min @ 80 bar – pump 1
3/8" QRC 0-6 l/min @ 70 bar – pump 1
3/8" QRC 0-6 l/min @ 135 bar – pump 2
(Variable using control valves)

Engine

Single cylinder, air cooled diesel
Maximum power 7.4 kW @ 3600 rpm
Operating speed Variable up to 3600 rpm
Hand starting Recoil
Electric starting Key ignition
12V battery charged via 12V alternator on engine
Fuel tank 4.7 litre
Running time 4.5 hours at 50% load

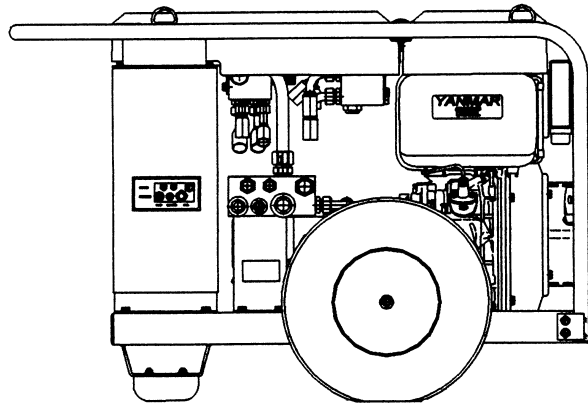

Shipping Details

Length 121cm
Width 78cm
Height 94cm
Weight 211Kg

Optional Accessories

Spark arrestor (KA/5041)
Chalwyn valve (KA/5076)
GRP Covers (KA/5056)
Overall PVC cover for GP10 P/Pack Standard (8072CV)
Overall PVC cover for GP10 P/Pack c/w safety devices (8071CV)
Hand start spares kit (SK/0134)
Electric start spares kit (SK/0134)
Lifting Sling (LS/4619)

powerpacks

Hydraulics

Single gear pump driven at engine speed	
Hydraulic tank capacity	38 litres (hydraulic oil not supplied)
Filtering	Re-usable suction strainer Return filter
Hydraulic connections	Quick release couplings (QRCs) Pressure female Return male

Instrumentation / Controls

Double output flow control block
Pump manual by-pass
Oil level / temperature gauge
Pressure relief valve

Engine

Speed / Stop control
Exhaust decompressor